

# Canon *Canonet* Service Manual



*Includes:*

Canonet 1, 2, 3 (1962)

# CANON REPAIR MANUAL

CANONET

(REFERENCE NO. C-30208)

CANON CAMERA COMPANY, INC.

TOKYO, JAPAN

## TABLE OF CONTENTS

TOP COVER	1,7
SHUTTER BUTTON	1
BASE PLATE	1
TRIGGER LEVER	1
REWIND CRANK	1
REWIND CLUTCH LEVER	1
SOME BASIC PARTS	1,2
FILM COUNTER	2,7
RANGE-VIEWFINDER OPTICAL SYSTEM	2,3
EXPOSURE METER	2,6,8
BACK COVER	4
TAKE-UP SPOOL & SPROCKET	4
BODY CASE	4
WINDING MECHANISM	4,5
OBJECTIVE LENS.	6

EXPLODED VIEW

of

CANONET

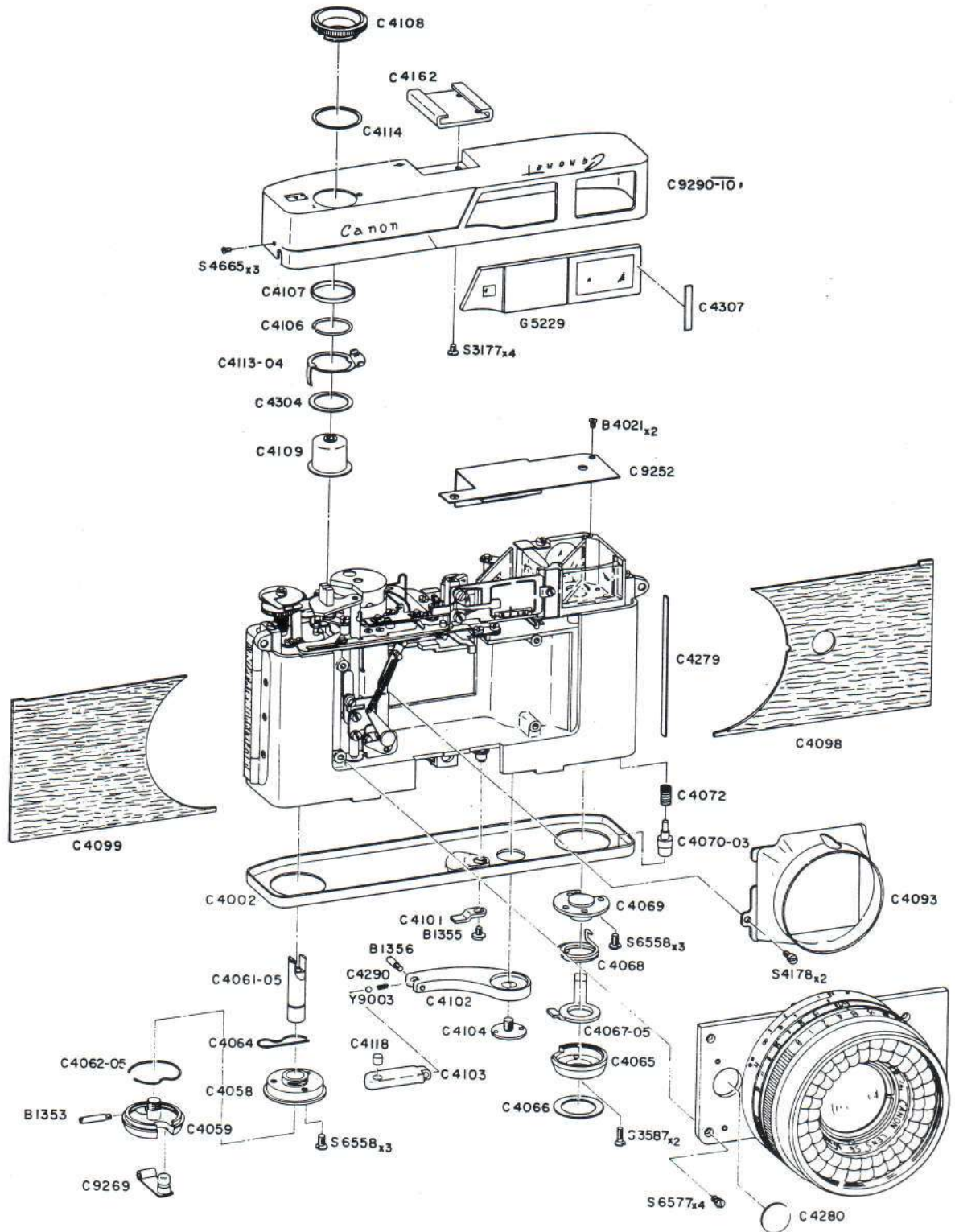

## PARTS LIST

**TOP COVER (cf.p.7)**

C 9290-10 Top Cover (B. P.)  
 C 4162 Accessory Shoe  
 C 4307 Liner  
 G 5229 Front Glass  
 S 3177 Screwx4  
 S 4665 Screwx3

**SHUTTER BUTTON**

C 4106 Retainer  
 C 4107 Ring  
 C 4108 Time Ring  
 C 4109 Shutter Button  
 C 4113-04 Stopper  
 C 4114 Washer  
 C 4304 Light Shield

**BASE PLATE**

C 4002 Base Plate  
 C 4065 Cover  
 C 4066 Leather Cover  
 C 4067-05 Lever  
 C 4068 Spring  
 C 4069 Tripod Socket  
 C 4070-03 Safety Lock  
 C 4072 Spring  
 S 3587 Screw x 2  
 S 6558 Screw x3

**TRIGGER LEVER**

C 4102 Trigger Lever  
 C 4103 Trigger Knob  
 C 4104 Pin Face Screw  
 C 4118 Cushion  
 C 4290 Coil Spring  
 B 1356 Screw  
 Y 9003 Steel Ball

**REWIND CRANK**

C 9269 Rewind Crank (B. P.)  
 C 4058 Bearing  
 C 4059 Rewind Knuckle  
 C 4061-05 Rewind Fork  
 C 4062-05 Spring  
 C 4064 Spring  
 B 1353 Screw  
 S 6558 Screw x3

**REWIND CLUTCH LEVER**

C 4101 Film Rewind Clutch Lever  
 B 1355 Screw

**SOME BASIC PARTS**

C 9252 Cover Plate (B. P.)  
 C 4093 Light Shield  
 C 4098 Leather Cover (Front-Left)  
 C 4099 Leather Cover (Front-Right)  
 C 4279 Light Shield  
 C 4280 Cap  
 B 4021 Screw x2  
 S 4178 Screw x2  
 S 6577 Screw x4

EXPLODED VIEW

of

CANONET

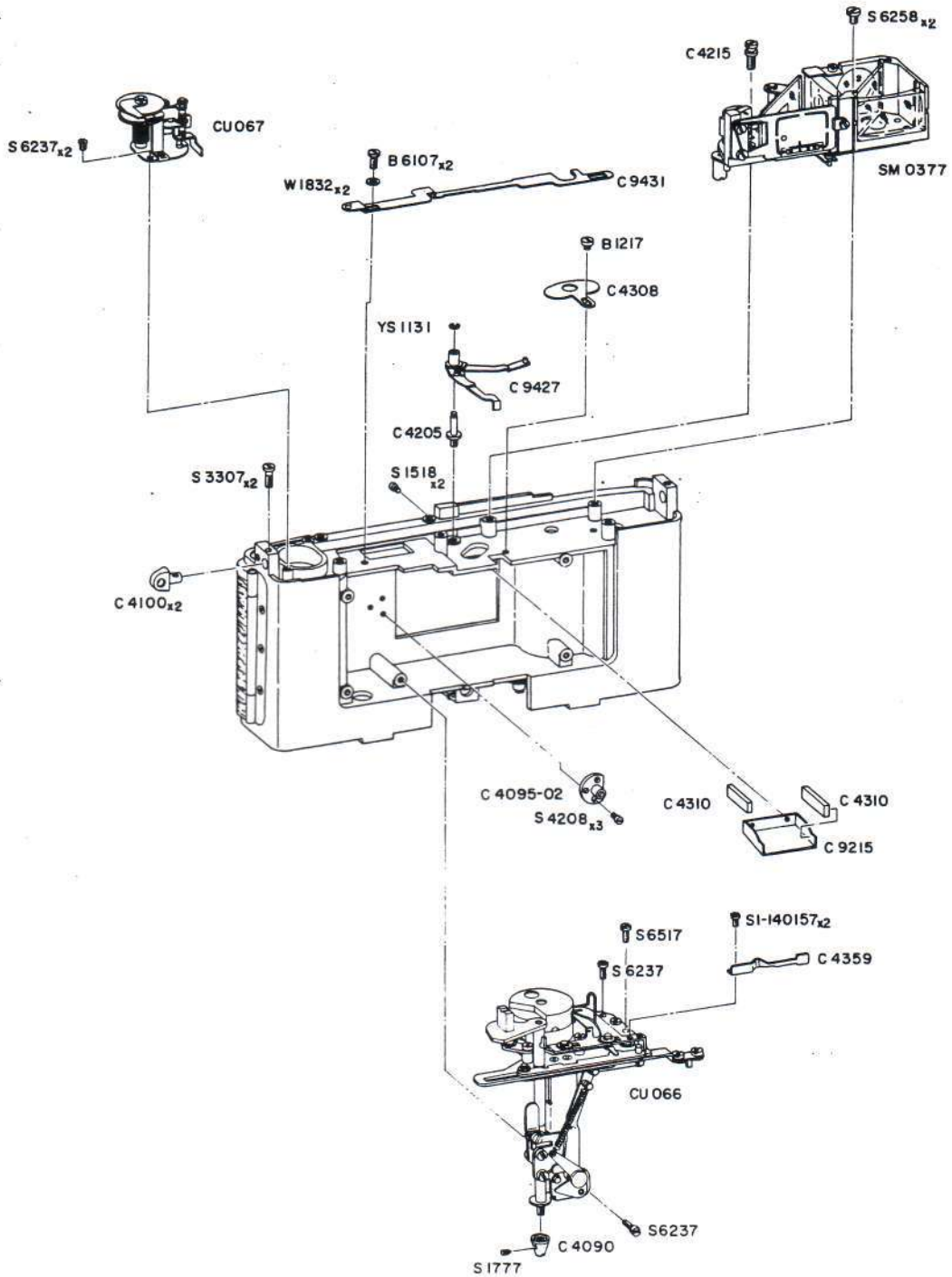

## PARTS LIST

## FILM COUNTER (cf.p.7)

CU 067	Film Counter (Unit)
C 9431	Film Counter Advancing Lever (B. P.)
B 6107	Screw x2
S 6237	Screw x 2
W 1832	Washer x 2

## RANGE-VIEWFINDER OPTICAL SYSTEM (cf.p.3)

SM 0377	Range-Viewfinder Optical System (Unit)
C 9427	Lever (B. P.)
C 4205	Shaft Screw
C 4215	Screw
S 6258	Screw x2
YS 1131	Retaining Washer

## EXPOSURE METER (cf.pp.6&amp;8)

CU 066	Exposure Meter (Unit)
	(Contains <u>ES 4003</u> : Photoelectric Cell)
C 4090	Cone
C 4095-02	Bearing
C 4359	EE-Signal
S 1777	Screw
S 4208	Screw x3
S 6237	Screw x2
S 6517	Screw
S1-140157	Screw x2

## SOME BASIC PARTS

C 9215	Light Shield (B.P.)
C 4100	Neck Strap Adapter x 2
C 4308	Light Shield
C 4310	Light Shield x 2
B 1217	Screw
S 1518	Screw x 2
S 3307	Screw x 2

EXPLODED VIEW  
of  
CANONET

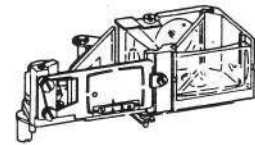

SM0377

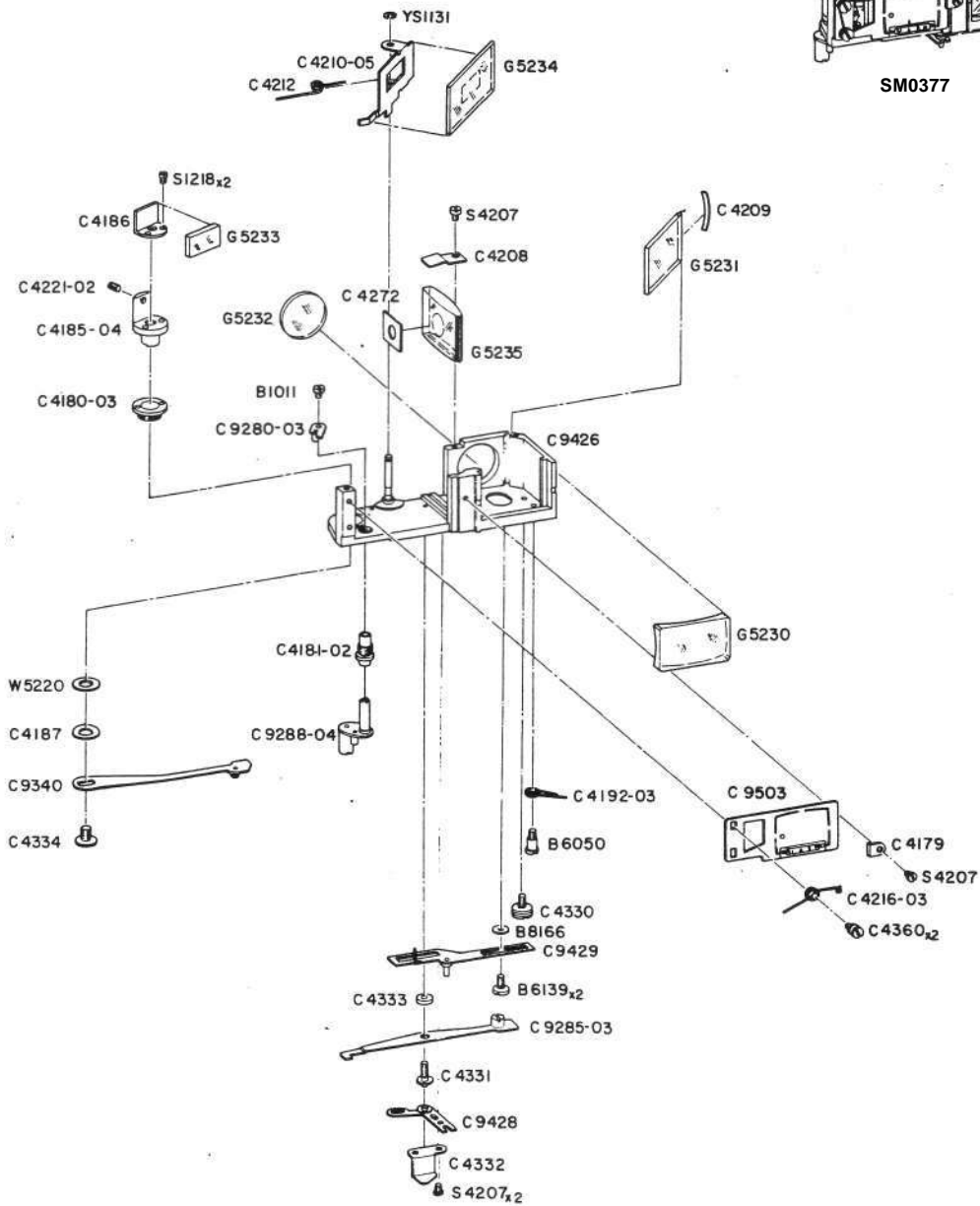



## PARTS LIST

## RANGE-VIEWFINDER OPTICAL SYSTEM (cf.p. 2)

SM 0377 Range-Viewfinder Optical System(Unit)

C 9280-03 Lever (B.P.)  
 C 9285-03 Lever (B. P.)  
 C 9288-04 Focusing Lever (B. P.)  
 C 9340 Lever (B. P.)  
 C 9426 Base (B. P.)  
 C 9428 Connector (B. P.)  
 C 9429 Aperture Index Guide (B. P.)  
 C 9503 Viewfinder Mask (B. P.)  
 C 4179 Holder  
 C 4180-03 Bearing  
 C 4181-02 Bearing  
 C 4185-04 Mirror Base  
 C 4186 Mirror Holder  
 C 4187 Wave Washer  
 C 4192-03 Spring  
 C 4208 Pressure Plate  
 C 4209 Spring  
 C 4210-05 Supporter for Mirror  
 C 4212 Spring  
 C 4216-03 Spring  
 C 4221-02 Adjusting Screw  
 C 4272 Mask  
 C 4330 Stopper Pin  
 C 4331 Screw  
 C 4332 Pressure Plate  
 C 4333 Roller  
 C 4334 Screw  
 C 4360 Guide x 2  
 B 1011 Screw  
 B 6050 Screw  
 B 6139 Screw x 2  
 B 8166 Washer  
 G 5230 Viewfinder Lens  
 G 5231 Half Mirror  
 G 5232 Eyepiece  
 G 5233 Mirror  
 G 5234 Parallax Correcting Mirror  
 G 5235 Double Focus Lens  
 S 1218 Screw x 2  
 S 4207 Screw x 4

W 5220  
 W 5221  
 JW 5222

WasherxN

YS 1131

Retaining Washer

EXPLODED VIEW

of

CANONET

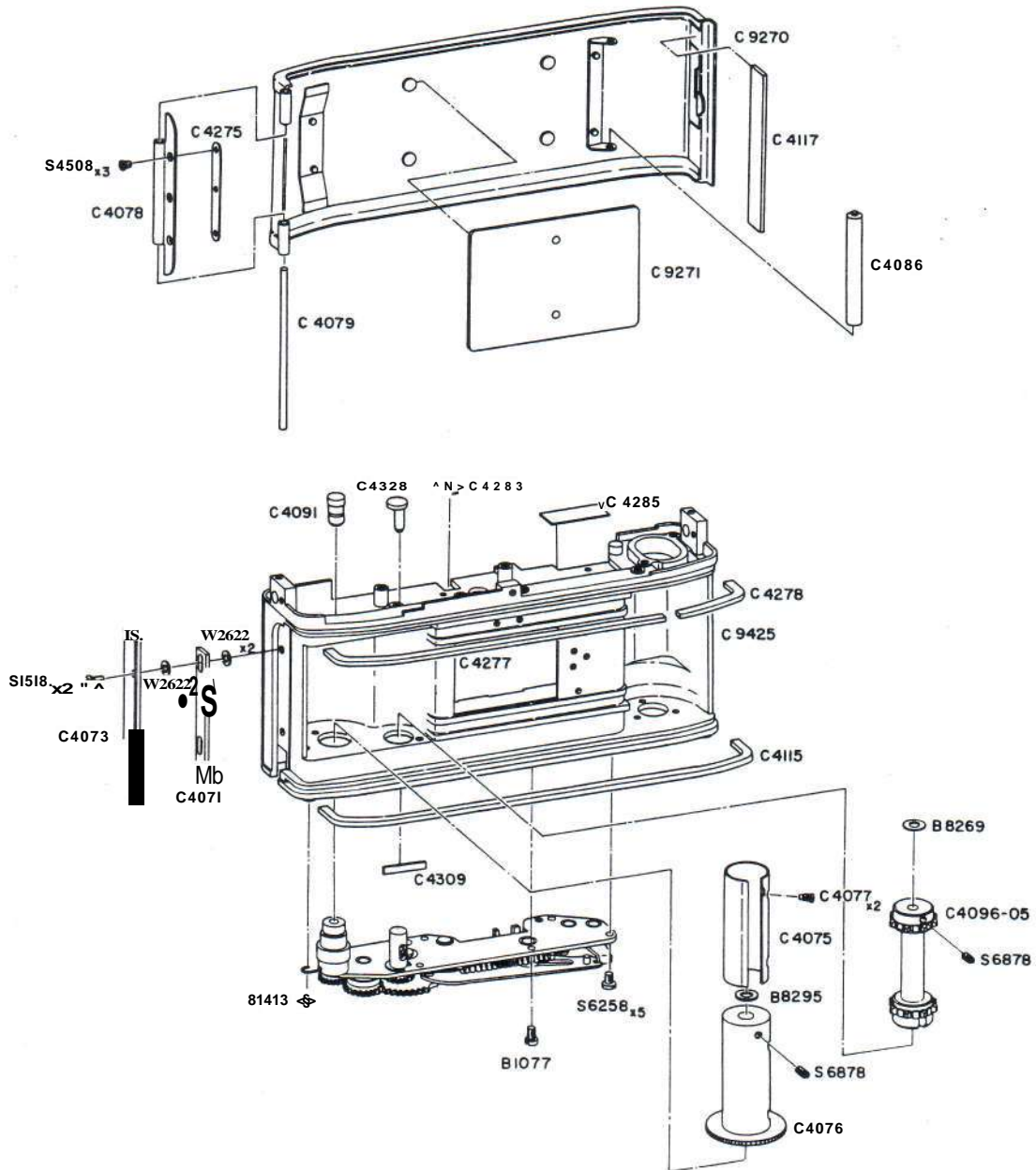

## PARTS LIST

## BACK COVER

C 9270 Back Cover (B. P.)  
C 9271 Pressure Plate (B. P.)  
C 4078 Hinge  
C 4079 Shaft of Hinge  
C 4086 Anti-Curl Roller  
C 4117 Light Shield  
C 4275 Washer  
S 4508 Screw x 3

## TAKE-UP SPOOL &amp; SPROCKET

C 4075 Take-Up Spool  
C 4076 Take-Up Spool Shaft  
C 4077 Screw x 2  
C 4091 Shaft  
C 4096-05 Sprocket  
C 4328 Eccentric Disk  
B 8269^ Washer x N  
B 8270J  
B 8295 Washer x N  
S 6878 Screw x 2

## BODY CASE

C 9425 Body Case (B. P.)  
C 4071 Hook  
C 4073 Hook Cover  
C 4115 Light Shield  
C 4277 Light Shield  
C 4278 Light Shield  
C 4283 Light Shield  
C 4285 Light Shield  
C 4309 Light Shield  
S 1518 Screw x 2  
W 2622 Washer >.4

## WINDING MECHANISM (cf.p.5)

B 1077 Screw  
B 1413 Screw  
S 6258 Screw X5

### EXPLODED VIEW

of

### CANONET

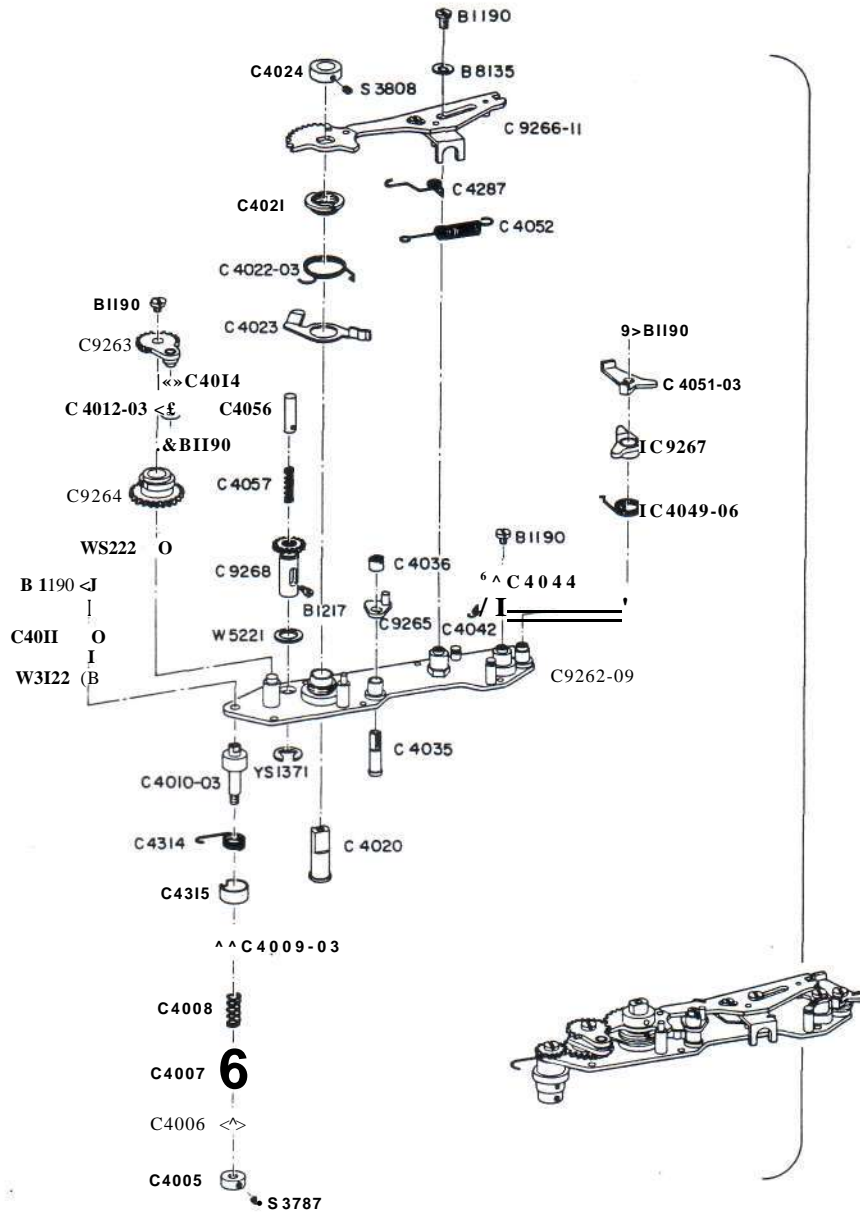

## PARTS LIST

<b>WINDING MECHANISM</b> (cf. p.4)		<b>W 5222</b>	Washer xN
		<b>YS 1371</b>	Retaining Washer
C 9262-09	Base Plate (B. P.)		
C 9263	Gear (B. P.)		
C 9264	Feeding Gear (B. P.)		
C 9265	Film Rewind Release Lever (B. P.)		
C 9266-11	Wind Device (B. P.)		
C 9267	Lever (B. P.)		
C 9268	Sprocket Gear (B. P.)		
C 4005	Collar		
C 4006	Washer		
C 4007	Cover		
C 4008	Spring		
C 4009-03	Cover		
C 4010-03	Wind Shaft for Spool Gear		
C 4011	Gear		
C 4012-03	Feeding Claw		
C 4014	Spring		
C 4020	Wind Lever Shaft		
C 4021	Pin Face Nut		
C 4022-03	Spring		
C 4023	Clutch Lever		
C 4024	Collar		
C 4035	Shaft Screw		
C 4036	Nut		
C 4042	Spring		
C 4044	Lever		
C 4049-06	Spring		
C 4051-03	Lever		
C 4052	Spring		
C 4056	Clutch Shaft		
C 4057	Spring		
C 4287	Spring		
C 4314	Spring		
C 4315	Collar		
B 1190	Screw x 6		
B 1217	Screw		
B 8135	Washer		
S 3787	Screw		
S 3808	Screw		
pV 312rj	Washer xN		
LW 3122J			
W 5221	Washer		

EXPLODED VIEW  
of  
CANONET

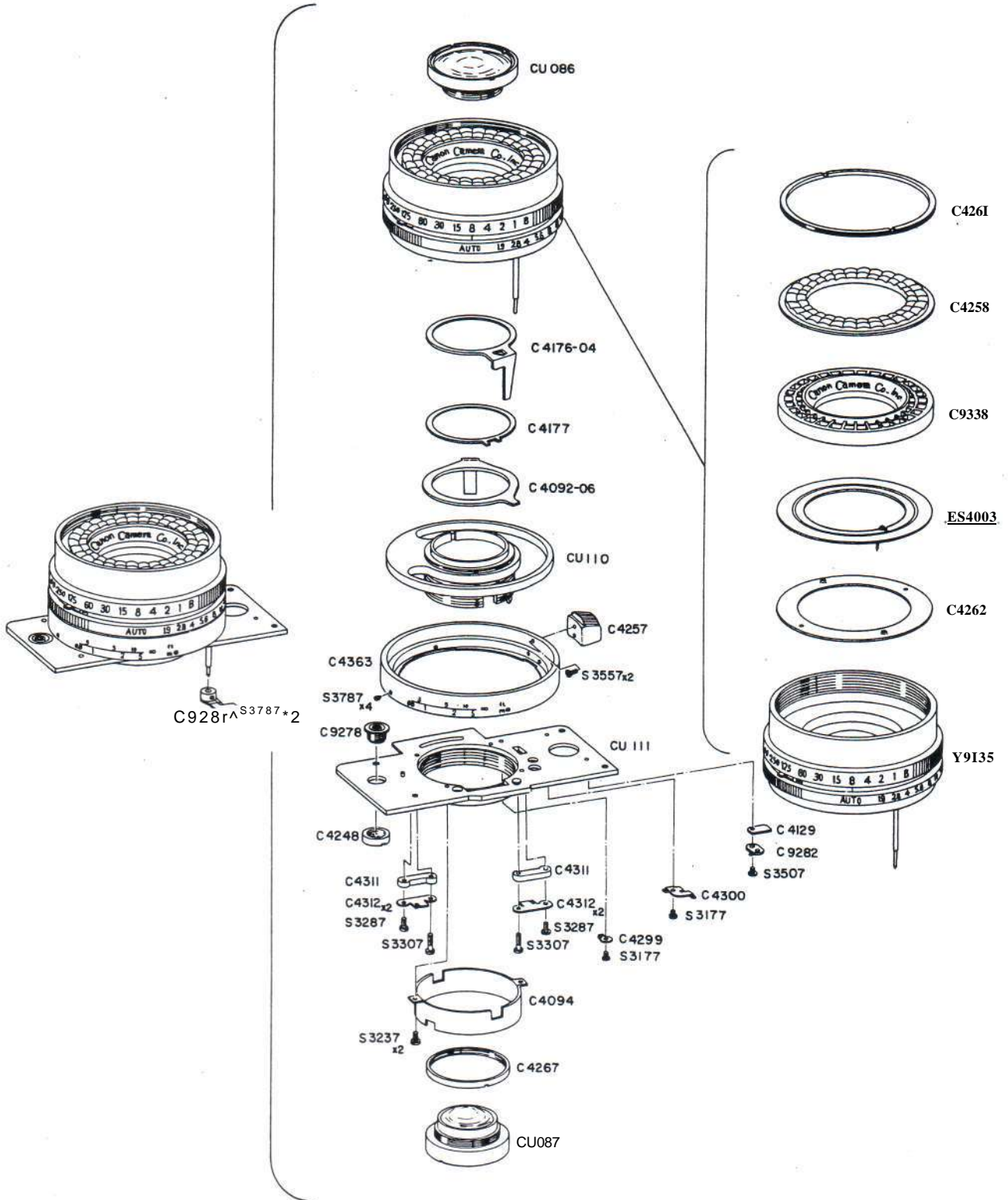

## PARTS LIST

## OBJECTIVE LENS

CU 086	Front Lens (Unit)
CU 087	Rear Lens (Unit)
CU 110	Helicoid (Unit)
CU 111	Front Panel (Unit)
C 9278	Flash Socket (B. P.)
C 9281	Lever (B. P.)
C 9282	Contact (B. P.)
C 9338	Lattice Window Frame (B. P.)
C 4092-06	Ring for Shutter Charge
C 4094	Light Shield
C 4129	Insulator
C 4176-04	Ring for Shutter Release
C 4177	Intermediate Ring
C 4248	Nut
C 4252	Flange
C 4257	Focusing Knob
C 4258	Window
C 4261	Assemble Collar
C 4262	Pressure Plate
C 4267	Collar
C 4299	Cord Holder
C 4300	Cord Holder
C 4311	Guide Holder x 2
C 4312	Guidex4
C 4363	Focusing Ring
S 3177	Screwx2
S 3237	Screwx2
S 3287	Screw x 2
S 3307	Screw x2
S 3507	Screw
S 3557	Screw x2
S 3787	Screw x 6
Y 9135	Shutter Unit

## EXPOSURE METER (cf. pp. 2 &amp; 8)

ES 4003 Photoelectric Cell is included in  
CU 066 Exposure Meter and is not supplied  
as a separate part.

EXPLODED VIEW  
of  
CANONET

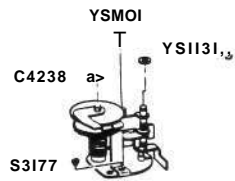
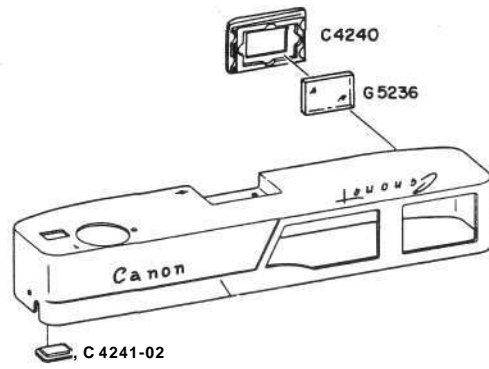



PARTS LIST

TOP COVER (cf. p. 1)

C 4240      Eyepiece Holder  
C 4241-02    Film Counter Window  
G 52^6      Eyepiece

FILM COUNTER (cf. p. 2)

C 4238      Nut  
S 3177      Screw  
YS 1101     Retaining Washer  
YS 1131     Retaining Washer x 3

EXPLODED VIEW  
of  
CANONET

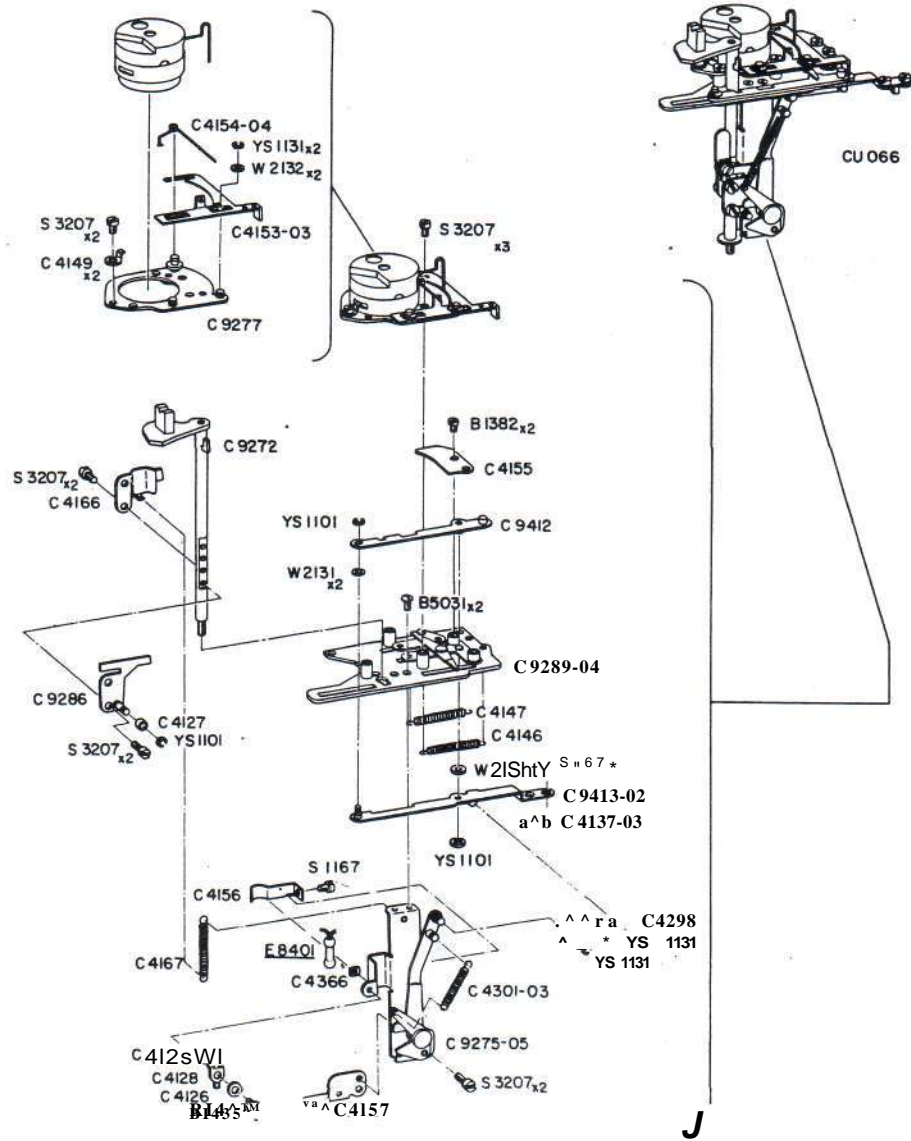

## PARTS LIST

**EXPOSURE METER (cf.pp.2 & 6)**

CU 066	Exposure Meter (Unit)
C 9272	Shutter Shaft (B. P.)
C 9275-05	Drive Lever Unit (B. P.)
C 9277	Base (B. P.)
C 9286	Lever for Shutter Release (B. P.)
C 9289-04	EE-Calculator (B. P.)
C 9412	Moving Arm (B. P.)
C 9413-02	Moving Arm (B. P.)
C 4125	Insulator
C 4126	Insulator
C 4127	Collar
C 4128	Contact
C 4137-03	Lever for Mask
<b>C</b> 4146	Coil Spring
<b>C</b> 4147	Coil Spring
<b>C</b> 4149	Galvanometer Holder x 2
<b>C</b> 4153-03	Moving Guide
<b>C</b> 4154-04	Spring
<b>C</b> 4155	Cam
<b>C</b> 4156	Resistor Holder
<b>C</b> 4157	Bearing for Shutter Shaft
<b>C</b> 4166	Spring Holder
<b>C</b> 4167	Coil Spring
<b>C</b> 4298	Connecting Rod
<b>C</b> 4301-03	Coil Spring
<b>C</b> 4366	Nut
B 1382	Screw x 2
B 1435	Screw
B 5031	Screw x 2
S 1167	Screw x3
S 3207	Screw x 11
W 2131	Washer x 4
W 2132	Washer x 2
YSI 1101	Retaining Washer x 3
YSI 1131	Retaining Washer x 4

## INDEX OF PART NUMBERS

PART NO.	PAGE	PART NO.	PAGE	PART NO.	PAGE	PART NO.	PAGE
CU 066	2,8	C 9431	2	C 4079	4	C 4205	2
CU 067	2	C 9487	1	C 4086	4	C 4208	3
CU 086	6	C 9488	4	C 4090	2	C 4209	3
CU 087	6	C 9503	3	C 4091	4	C 4210-05	3
CU 110	6			C 4092-06	6	C 4212	3
CU 111	6			C 4093	1	C 4215	2
				C 4094	6	C 4216-03	3
				C 4095-02	2	C 4221-02	3
				C 4096-05	4	C 4238	7
		C 4002	1	C 4098	1	C 4240	7
		C 4005	5	C 4099	1	C 4241-02	7
SM 0377	2,3	C 4006	5	C 4100	2	C 4248	6
		C 4007	5	C 4101	1	C 4257	6
		C 4008	5	C 4102	1	C 4258	6
		C 4009-03	5	C 4103	1	C 4261	6
		C 4010-03	5	C 4104	1	C 4262	6
		C 4011	5	C 4106	1	C 4267	6
		C 4012-03	5	C 4107	1	C 4272	3
C 9215	2	C 4014	5	C 4108	1	C 4275	4
C 9252	1	C 4020	5	C 4109	1	C 4277	4
C 9262-09	5	C 4021	5	C 4113-04	1	C 4278	4
C 9263	5	C 4022-03	5	C 4114	1	C 4279	1
C 9264	5	C 4023	5	C 4115	4	C 4280	1
C 9265	5	C 4024	5	C 4117	4	C 4283	4
C 9266-11	5	C 4035	5	C 4118	1	C 4285	4
C 9267	5	C 4036	5	C 4125	8	C 4287	5
C 9268	5	C 4042	5	C 4126	8	C 4290	1
C 9269	1	C 4044	5	C 4127	8	C 4298	8
C 9270	4	C 4049-06	5	C 4128	8	C 4299	6
C 9271	4	C 4051-03	5	C 4129	6	C 4300	6
C 9272	8	C 4052	5	C 4137-03	8	C 4301-03	8
C 9275-05	8	C 4056	5	C 4146	8	C 4304	1
C 9277	8	C 4057	5	C 4147	8	C 4307	1
C 9278	6	C 4058	1	C 4149	8	C 4308	2
C 9280-03	3	C 4059	1	C 4153-03	8	C 4309	4
C 9281	6	C 4061-05	1	C 4154-04	8	C 4310	2
C 9282	6	C 4062-05	1	C 4155	8	C 4311	6
C 9285-03	3	C 4064	1	C 4156	8	C 4312	6
C 9286	8	C 4065	1	C 4157	8	C 4314	5
C 9288-04	3	C 4066	1	C 4162	1	C 4315	5
C 9289-04	8	C 4067-05	1	C 4166	8	C 4316	1
C 9290-10	1	C 4068	1	C 4167	8	C 4317	1
C 9338	6	C 4069	1	C 4176-04	6	C 4318	6
C 9340	3	C 4070-03	1	C 4177	6	C 4322	6
C 9412	8	C 4071	4	C 4179	3	C 4323	1
C 9413-02	8	C 4072	1	C 4180	3	C 4325	1
C 9425	4	C 4073	4	C 4181-02	3	C 4328	4
C 9426	3	C 4075	4	C 4185-04	3	C 4330	3
C 9427	2	C 4076	4	C 4186	3	C 4331	3
C 9428	3	C 4077	4	C 4187	3	C 4332	3
C 9429	3	C 4078	4	C 4192-03	3	C 4333	3

PART NO.	PAGE	PART NO.	PAGE	PART NO.	PAGE
C 4334	3	S 1167	8	Y 9003	1
C 4359	2	S 1218	3	Y 9134	6
C 4360	3	S 1518	2,4	Y 9135	6
C 4363	6	S 1777	2		
C 4364	6	S.3177	1,6,7		
C 4366	8	S 3207	8		
		S 3237	6		
		S 3287	6		
		S 3307	2,6	YS 1101	7,8
		S 3507	6	YS 1131	2,3,7,8
		S 3557	6	YS 1371	5
B 1011	3	S 3587	1		
B 1077	4	S 3787	5,6		
B 1190	5	S 3808	5		
B 1217	2,5	S 4178	1		
B 1353	1	S 4207	3		
B 1355	1	S 4208	2		
B 1356	1	S 4508	4		
B 1382	8	S 4665	1		
B 1413	4	S 6237	2		
B 1435	8	S 6258	2,4		
B 4021	1	S 6517	2		
B 5031	8	S 6558	1		
B 6050	3	S 6577	1		
B 6107	2	S 6878	4		
B 6139	3	Sl-140157	2		
B 8135	5				
B 8166	3				
B 8269	4				
B 8270	4				
B 8295	4				
		W 1832	2		
		W 2131	8		
		W 2132	8		
		W 2622	4		
<u>E 8401</u>	8	W 3121	5		
<u>ES 4003</u>	6	W 3122	5		
		W 5220	3		
		W 5221	3,5		
		W 5222	3,5		
G 5229	1				
G 5230	3				
G 5231	3				
G 5232	3				
G 5233	3				
G 5234	3				
G 5235	3				
G 5236	1				

**CANON REPAIR MANUAL**

**SHUTTER for CANONET 1.2**

(REF.NO. 1-30202)

(REF.NO. 1-30206)

**CANON CAMERA CO., INC.**

**TOKYO, JAPAN**

EXPLODED VIEW  
of  
SHUTTER for CANONET 1.2

REF. NO. 1-30202  
REF. NO. 1-30206

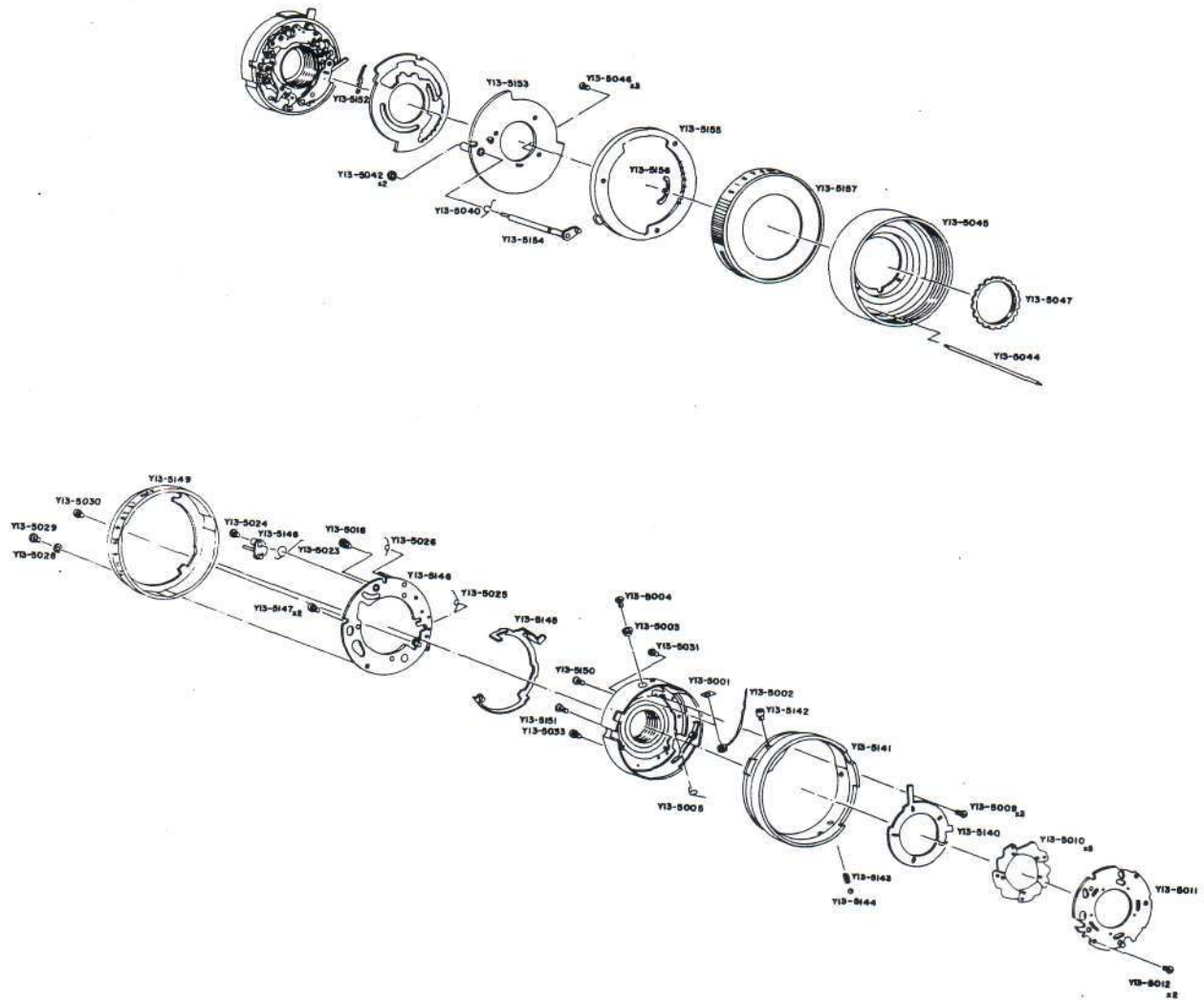

REF. NO. 1-30202

REF. NO. 1-30206

1

## PARTS LIST

Y13-5001	Insulator Sheet
Y13-5002	Flash Lead Wire
Y13-5003	Insulator Bush
Y13-5004	Screw
Y13-5005	Spring
Y13-5009	Screw x 3
Y13-5010	Diaphragm Blade x 5
Y13-5011	Blade Retaining Plate
Y13-5012	Screw x 2
Y13-5018	Screw
Y13-5023	Spring
Y13-5024	Screw
Y13-5025	Spring
Y13-5026	Spring
Y13-5028	Washer
Y13-5029	Screw
Y13-5030(1.8)~	Adjusting Screw
Y13-5030(1.9)	Such numbers (1.8), (1.9)
/	and (2.6) indicate diame-
(	ter of Adjusting Screws.
\	There are some 9 kind of
j	screw begins with diame-
/	ter 1. 8^ increase 0. 1^
	each ends 2. b(j>.
Y13-5030(2.5)	Standard screw is
Y13-5030(2.6).	Y13-5030(20).
Y13-5031	Screw
Y13-5033	Screw
Y13-5040	Spring
Y13-5042	Retaining Washer x 2
Y13-5044	Lead Wire
Y13-5045	Hood Ring
Y13-5046	Screw x 3
Y13-5047	Nut
Y13-5140	Diaphragm Control Ring
Y13-5141	Marking Ring
Y13-5142	Screw x 3
Y13-5143	Coil Spring
Y13-5144	Steel Ball
Y13-5145	Contact Change Ring
Y13-5146	Rear Cover Plate
Y13-5147	Screw x 2
Y13-5148	Automatic Diaphragm Lever
Y13-5149	Aperture Scale Ring
Y13-5150	Screw
Y13-5151	Screw
Y13-5152	Click Spring
Y13-5153	Front Cover Plate
Y13-5154	Coupling Shaft
Y13-5155	ASA Cam Ring
Y13-5156	Click Spring
Y13-5157	Shutter Speed Ring



# **CANON REPAIR MANUAL**

**SHUTTER for CANONET 3**  
(REFERENCE NO.1-30208)

**CANON CAMERA COMPANY INC.**  
**TOKYO, JAPAN**

# EXPLODED VIEW of SHUTTER for CANONET 3

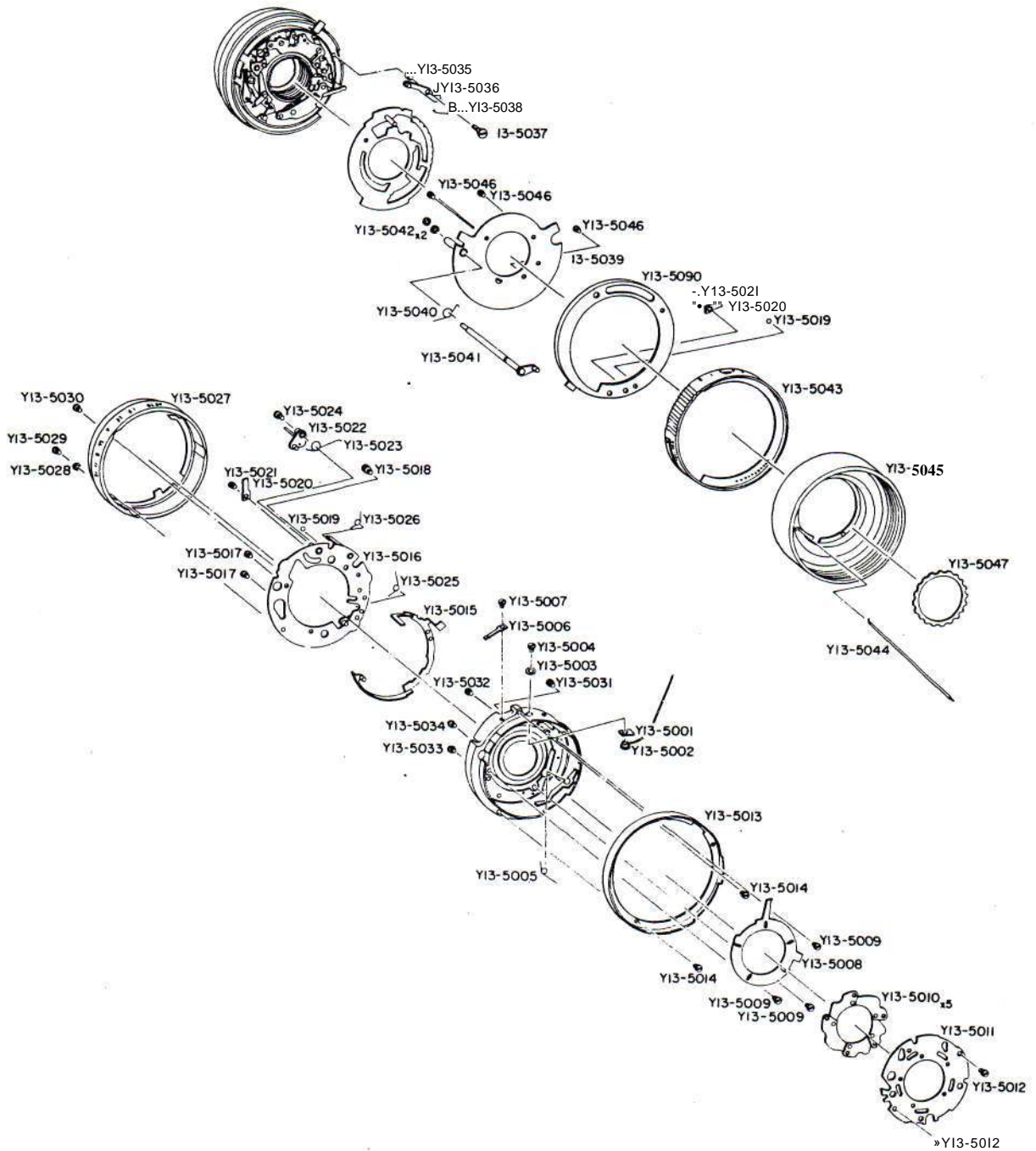

## PARTS LIST

Y13-5001	Insulator Sheet	Y13-•5044	Lead Wire
Y13-5002	Flash Lead Wire	Y13--5045	Hood Ring
Y13-5003	Insulator Bush	Y13-•5046	Screw x 3
Y13-5004	Screw	Y13-•5047	Nut
Y13-5005	Spring	Y13-•5090	ASA Cam Ring
Y13-5006	Click Spring		
Y13-5007	Sc rew		
Y13-5008	Diaphragm Control Ring		
Y13-5009	Screw x 3		
Y13-5010	Diaphragm Blade x 5		
Y13-5011	Blade Retaining Plate		
Y13-5012	Screw x 2		
Y13-5013	Marking Ring		
Y13-5014	Screw x 2		
Y13-5015	Contact Change Ring		
Y13-5016	Rear Cover Plate		
Y13-5017	Screw x 2		
Y13-5018	Screw		
Y13-5019	Steel Ball x 2		
Y13-5020	Click Spring x 2		
Y13-5021	Screw x 2		
Y13-5022	Automatic Diaphragm Lever		
Y13-5023	Spring		
Y13-5024	Screw		
Y13-5025	Spring		
Y13-5026	Spring		
Y13-5027	Diaphragm Regulating Ring		
Y13-5028	Washer		
Y13-5029	Screw		
Y13-5030(1. 8)-]	Adjusting Screw		
Y13-5030(1. 9)	Such numbers (1. 8), (1. 9) and (2. 6) indicate diameter of adjusting Screws. There are some 9 Kind of Screw begins with diame- ter 1. 8 4 increase 0. 1 (j> each ends 2. 6 <&		
Y13-5030(2. 5)	Standard screw is		
Y13-5030(2. 6)	Y13-5030(2. 0).		
Y13-5031	Screw		
Y13-5032	Screw		
Y13-5033	Screw		
Y13-5034	Screw		
Y13-5035	Spacer		
Y13-5036	B Lock Lever		
Y13-5037	Screw		
Y13-5038	Spring		
Y13-5039	Front Cover Plate		
Y13-5040	Spring		
Y13-5041	Coupling Shaft		
Y13-5042	Snap Ring x 2		
Y13-5043	Time Regulating Ring		

EXPLODED VIEW  
of  
SHUTTER for CANONET 3

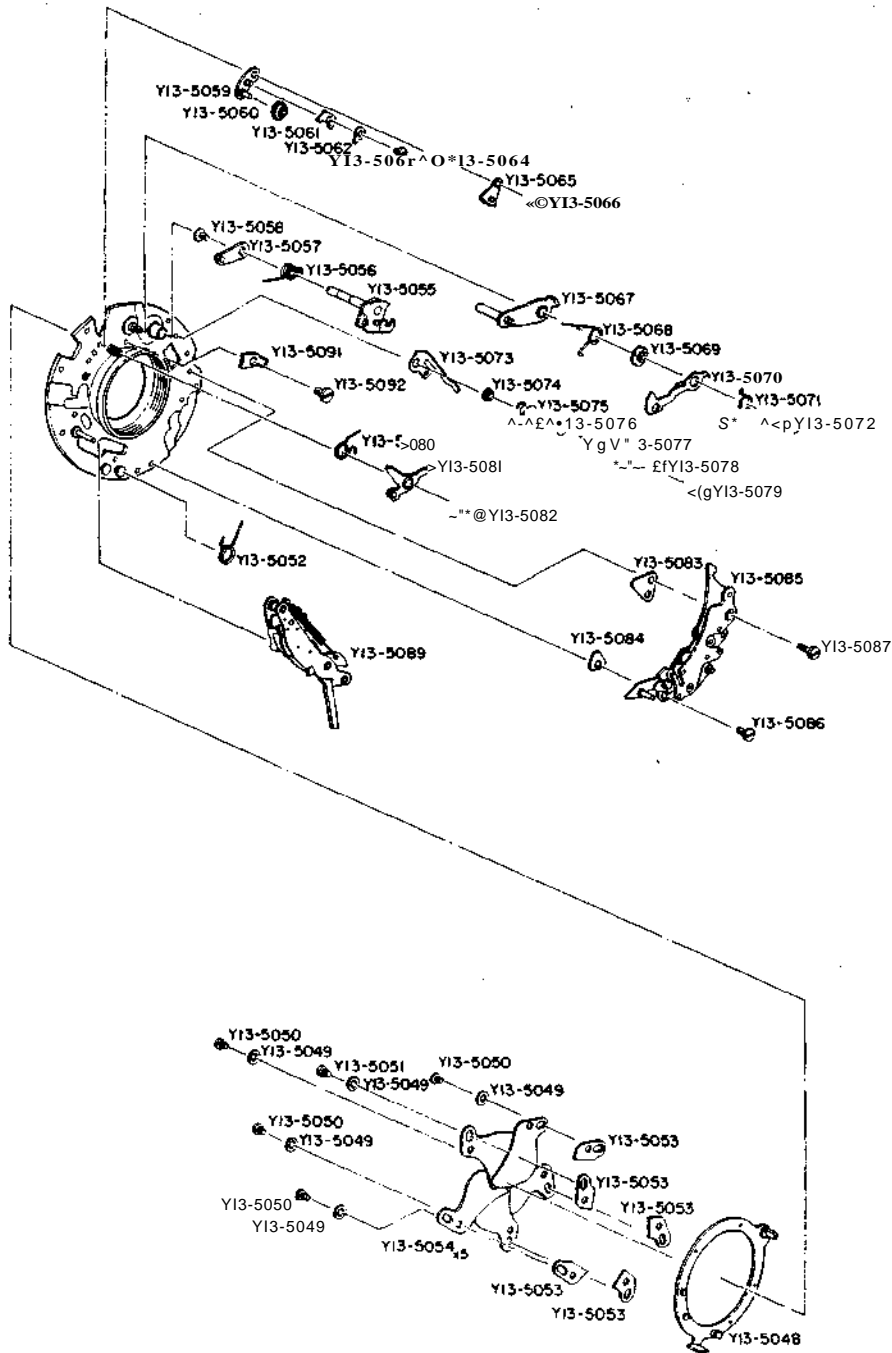

## PARTS LIST

Y13-5048	Sector Ring
Y13-5049	Washer x 5
Y13-5050	Screw x 3
Y13-5051	Screw x 2
Y13-5052	Spring
Y13-5053	Sub Shutter Blade x 5
Y13-5054	Shutter Blade x 5
Y13-5055	Main Cocking Lever
Y13-5056	Spring
Y13-5057	Rear Cocking Lever
Y13-5058	Screw
Y13-5059	M-Contact Governor Plate
Y13-5060	Cog-Wheel
Y13-5061	Anchor
Y13-5062	Cog-Wheel Supporter
Y13-5063	Screw
Y13-5064	Segment Gear Collar
Y13-5065	Segment Gear
Y13-5066	Screw
Y13-5067	Release Lever
Y13-5068	Spring
Y13-5069	M-Governor Regulating Ring
Y13-5070	M-Governor Driver
Y13-5071	Spring
Y13-5072	Fixing Nut
Y13-5073	X-Contact Spring
Y13-5074	Retainer for Contact Lever
Y13-5075	X-Contact Lever
Y13-5076	Contact Lever Washer
Y13-5077	M-Contact Lever
Y13-5078	Spring
Y13-5079	Screw
Y13-5080	Spring
Y13-5081	B Lever
Y13-5082	Screw
Y13-5083	Governor Sheet A
Y13-5084	Governor Sheet B
Y13-5085	Slow Governor
Y13-5086	Screw
Y13-5087	Screw
Y13-5089	Self-Timer
Y13-5091	Tension Stopper
Y13-5092	Screw

REF. NO. 1-30208

INDEX OF PARTS NUMBER

PART NO.	PAGE	PART NO.	PAGE
Y13-5001	1	Y13-5053	2
Y13-5002	1	Y13-5054	2
Y13-5003	1	Y13-5055	2
Y13-5004	1	Y13-5056	2
Y13-5005	1	Y13-5057	2
Y13-5006	1	Y13-5058	2
Y13-5007	1	Y13-5059	2
Y13-5008	1	Y13-5060	2
Y13-5009	1	Y13-5061	2
Y13-5010	1	Y13-5062	2
Y13-5011	1	Y13-5063	2
Y13-5012	1	Y13-5064	2
Y13-5013	1	Y13-5065	2
Y13-5014	1	Y13-5066	2
Y13-5015	1	Y13-5067	2
Y13-5016	1	Y13-5068	2
Y13-5017	1	Y13-5069	2
Y13-5018	1	Y13-5070	2
Y13-5019	1	Y13-5071	2
Y13-5020	1	Y13-5072	2
Y13-5021	1	Y13-5073	2
Y13-5022	1	Y13-5074	2
Y13-5023	1	Y13-5075	2
Y13-5024	1	Y13-5076	2
Y13-5025	1	Y13-5077	2
Y13-5026	1	Y13-5078	2
Y13-5027	1	Y13-5079	2
Y13-5028	1	Y13-5080	2
Y13-5029	1	Y13-5081	2
Y13-5030	1	Y13-5082	2
Y13-5031	1	Y13-5083	2
Y13-5032	1	Y13-5084	2
Y13-5033	1	Y13-5085	2
Y13-5034	1	Y13-5086	2
Y13-5035	1	Y13-5087	2
Y13-5036	1	Y13-5089	2
Y13-5037	1	Y13-5090	1
Y13-5038	1	Y13-5091	2
Y13-5039	1	Y13-5092	2
Y13-5040	1		
Y13-5041	1		
Y13-5042	1		
Y13-5043	1		
Y13-5044	1		
Y13-5045	1		
Y13-5046	1		
Y13-5047	1		
Y13-5048	2		
Y13-5049	2		
Y13-5050	2		
Y13-5051	2		
Y13-5052	2		

# CANON REPAIR GUIDE

CANONET

(REFERENCE NO. C-30206)

CANON CAMERA COMPANY, INC.

TOKYO, JAPAN

## TABLE OF CONTENTS

### RANGE-VIEWFINDER

When the double-image of the Range-Viewfinder does not align. ....	4
When the Viewfinder Mask does not move smoothly. ....	4
When the Aperture Scale Indicator inside the Range-Viewfinder out of order. ....	4
When the Red Mark does not appear normally. ....	5

### EXPOSURE METER

When the Exposure Meter does not work. ....	6
---	---

### FILM COUNTER

When the Film Counter does not move forward. ....	7
When the Film Counter does not return. ....	7

### WINDING MECHANISM

When the Shutter does not charge. ....	8
When the Trigger Lever does not move. ....	8
When the Trigger Lever runs idle or when it winds many times before the Shutter Button is pressed down. ....	8
When the Shutter Button cannot be pressed down. ....	9
When the Shutter Button does not return to its original position. ....	9
When the film cannot be rewound or when the film catches. ....	9

### INCORRECT FOCUS

When the back focus becomes out of focus. ....	10
When the double-image of the Range-Viewfinder does not align. ....	10



## RANGE-VIEWFINDER

When the double-image of the Range-Viewfinder does not align, it should be adjusted in the following manner:

Turn Screw C4221 when the deviation of the double-image is vertical.

Turn the Eccentric Screw of Lever C9285 to right or left when the deviation of the double-image is horizontal.

Care must be taken not to turn C4221 and the Eccentric Screw of C9285 too far as the screw thread may become worn or its calking may become loosened.

Cover Plate C9252 need not be removed when adjusting the double-image.

See *Repair Manual* p.3.

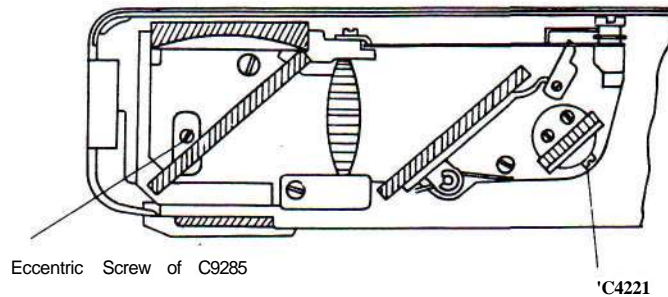

When the Finder Mask does not move smoothly even after turning the Focusing Ring, the following adjustments should be made.

1. Check to see if Spring C4216 has become weak. If so, bend C4216 to give it more strength, or replace it with a new one.

See *Repair Manual* p.3.

2. When the pressure of Holder C4179 is too strong, bend C4179 to weaken it.

See *Repair Manual* p.3.

3. When Viewfinder Mask C9430 is touching Cover Plate C9252, make the proper corrections by bending C9252.

See *Repair Manual* pp.1 S3.

4. If Viewfinder Mask C9430 is touching Aperture Scale Index C9429 or EE-Signal C4359, bend either C9429 or C4359 so that there will be a gap of approximately 1 mm.

See *Repair Manual* pp.2&3.

When the Aperture Scale Indicator inside the Range-Viewfinder out of order, the following adjustments should be made:

1. Make necessary adjustments by turning the Eccentric Screw of Lever C9427. If after adjustment the needle should again become unaligned, it means that the calking of the Eccentric Screw has become loose. In this case, replace C9427.

See *Repair Manual* p.2.

2. If the needle of Aperture Scale Index C9429 is bent and is touching Viewfinder Mask C9430, adjust by bending the needle.

See *Repair Manual* p.3.

3. If Lever C9427 and Lever for Mask C4137 are out of place, adjustments should be made by bending C9427 upwards.

See Repair Manual pp.2&8.

4. If Lever C9427 and Arm C9428 are out of place the upward and downward play of both should be adjusted with a washer.

See Repair Manual pp.2&3.

5. If the movement of C9427 is impeded by Lever C9427 and Film Counter Advancing Lever C9431 pressing against it, C9431 should be bent and adjusted so that it will not touch.

See Repair Manual p.2.

When the Red Mark does not appear normally, that is, when the Red Mark appears even though the Shutter has been set for automatic photography, or when the Red Mark does not appear at all after the lens cap has been put on and the Shutter Button pressed, it may be assumed that something is wrong with the Red Mark itself. In this case, the following adjustments should be made:

1. If the movement of Moving Guide C4153 is bad, replace Washer W 2132 x 2, which is under Retaining Washer YS 1131x2 holding C4153, with one of less thickness.

See Repair Manual p.8.

2. Adjust the length of EE-Signal C4359 after loosening Screw SI-140157 x 2 securing C4359.

See Repair Manual p.2.

\* \* \*

## EXPOSURE METER

When the Shutter is not released even after the Shutter Button is pressed down for automatic photography with the shutter speed set at 1/125 or 1/250 in the bright sunlight, it may be assumed that the Exposure Meter has developed some kind of trouble. In this case, the following checks and adjustments should be made.

1. Check to see whether the meter needle is in the position shown in the figure with the lens cap on. Then take the lens cap off and see if the needle moves when the lens is pointed towards the light.

See Repair Manual p.2.

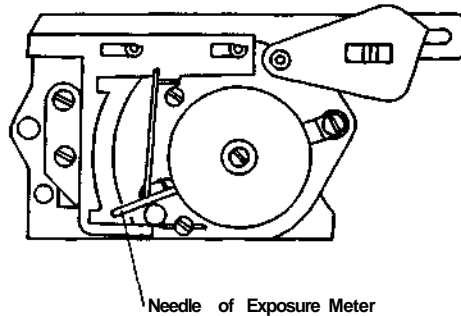

2. If the needle does not move, the connection between the photoelectric cell and the cord should be checked in the following order:
  - 1) Window C4258 and Lattice Window Frame C9338 are removed by disconnecting Collar C4261 with Tool T06A-C4261.
  - 2) Check whether the cord is firmly connected to Photoelectric Cell ES4003. Make sure that no naked wire is touching the inner side of ES4003.
  - 3) Before tightening C4261, press down on ES4003 with the hand and check to see if the needle moves when light is focussed on it.
3. If the above conditions are found to be normal but still the needle does not move, Exposure Meter CU066 should be replaced.

\* \* \*

## FILM COUNTER

If for some reason the Winding Mechanism becomes faulty and the Film Counter does not move forward, adjustments should be made in the following manner:

1. Check the Spring for Film Counter CU067 and reattach if it has come loose.

**See Repair Manual p.2.**

2. If the movement of the Stop Claw for CU067 is small, the Stop Claw will not mesh with the Ratchet Gear Teeth and this will prevent the Film Counter from moving forward. In this case, the tip of the Stop Claw should be bent.

**See Repair Manual p.2.**

When the Back Cover is opened the Film Counter will automatically return to "2", but if for some reason the Film Counter fails to return when the Back Cover is opened, adjustments should be made in the following manner:

Check to see if the Resetting Lever of Film Counter CU067 is not touching the camera body. If it is found to be touching the camera body, adjust by bending the Resetting Lever.

**See Repair Manual p.2.**

\* \* \*

## WINDING MECHANISM

When the camera shows the conditions described below, it may be assumed that the Winding Mechanism has become defective and so the following adjustments should be made:

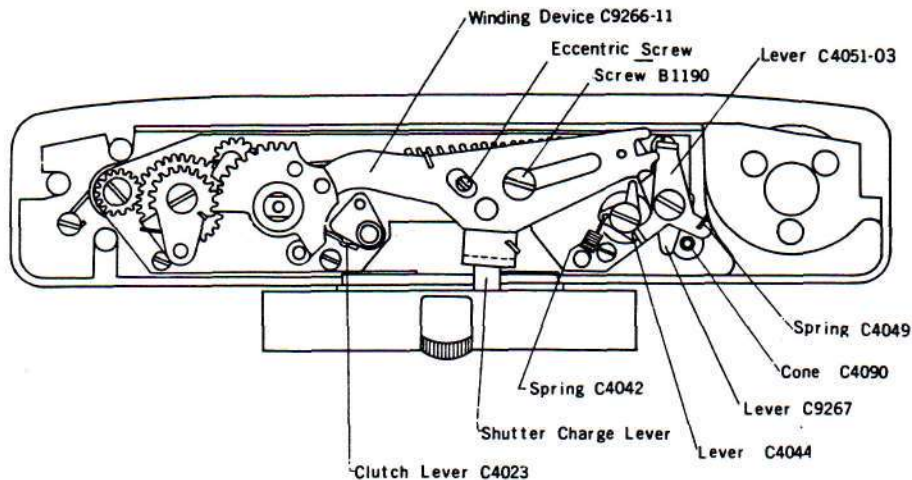

When the shutter is not charged even after the Trigger Lever is wound, the following adjustments should be made:

Loosen Screw B1190. float Winding Device C9266-11 and set the Shutter with a pair of tweezers.

Then adjust the amount of charge by turning the Eccentric Screw of C9266-11.

See Repair Manual p.5.

When the Trigger Lever does not move, the following checks and adjustments should be made:

1. Check to see whether the Screw for the Winding Device is loose.
2. Check to see whether Spring C4049 is out of place. If so, reattach.

See Repair Manual p.5.

3. If Cone C4090 is caught between Lever C9267 and Lever C4051-03. loosen Screw S1777 and adjust C4090 by turning it to the right.

See Repair Manual pp.2&5.

4. If Lever C4051-03 does not disengage itself from Lever C4044 when the shutter Nitron is pressed down because Cone C4090 does not go down enough, Screw S1777 should be loosened and adjustments made by turning C4090 to the left.

See Repair Manual pp.2&5.

When the Trigger Lever runs idle or when it winds many times before the shutter button is pressed down, the following checks and adjustments should be made:

1. Check to see whether Spring C4042 is out of place. If so. reattach.

See Repair Manual p.5

2. If the spindle of Lever C4044 is bent, replace Base Plate C9262-09.

See Repair Manual p.5

3. If the gap between Lever C4044 and Winding Device C9266-11 has become too wide because Lever C4044 has become worn out, adjustments should be made by turning the Hexagonal Eccentric Nut for Base Plate C9262-09 with Spanner-2 for C4041. If this is insufficient, C4044 should be replaced.

See Repair Manual p. 5

When the Shutter Button cannot be pressed down, it should be adjusted in the following manner:

Check to see whether Spring C4049 attached to Lever C4051-03 is out of place and if so, reattach.

See Repair Manual p. 5

When the Shutter Button does not return to its original position after it has been pressed down, the following adjustments should be made:

Check to see whether Cone C4090 is caught between Lever C9267 and Lever C4051-03. If so, loosen Screw SI 777 and make adjustments by turning C4090 to the right.

See Repair Manual pp. 2 & 5.

When the film cannot be rewound or when the film catches, the following adjustments should be made:

Open the Back Cover and set the Rewind Clutch Lever to R. Then check to see whether it will turn both to the left and right by rotating the sprocket manually. If it does not turn, see whether Clutch Lever C4023 is bent, or whether Clutch Shaft C4056 is held down properly by C4023. Then adjust by bending C4023, or replace C4023.

See Repair Manual p. 5.

\* \* \*

## INCORRECT FOCUS

When the Back Focus becomes out of focus due to some kind of shock, the following adjustments should be made with the use of 200mm T-Type Collimator:

First, loosen only three of the S3787x4 Screws holding Focusing Ring C4256, determine the proper position by turning C4256, and when the proper position is found, loosen the remaining one S3787 Screw.

Lastly, set the oo of C4256 to the camera's Range-Viewfinder Distance Scale and again tighten all four S3787x4 Screws.

See Repair *Manual* p. 6

When the double-image of the Range-Viewfinder does not align due to some kind of shock, adjustments should be made after referring to the paragraph on "When the Range-Viewfinder's Double-Image does not align?"

\* \* \*

**CANON REPAIR GUIDE.**

**SHUTTER for CANONET**

(REF.NO. 1-30208)

CANON CAMERA CO.,INC.

TOKYO, JAPAN



## CONTENTS

### Disassembling Method

Barrel .....	4
Shutter Blades .....	5
Diaphragm Blades .....	6
Diaphragm Ring .....	7

### Adjusting Method

Release Lever .....	g
M-Governor .....	10
Shutter Blades .....	11
Diaphragm Blades .....	14
Main Cocking Lever .....	15

### Trouble, Cause & Remedy

It cannot be released .....	18
Heavy Release .....	18
It can not be charged .....	19
Charge is heavy .....	20
Diaphragm blades do not return .....	20
Diaphragm blades do not return smoothly .....	21
B Full Open .....	21
B skips .....	22
One Second Open .....	22
Slow Skips .....	22
It cannot be released by self-timer .....	23

## BARREL DISASSEMBLING

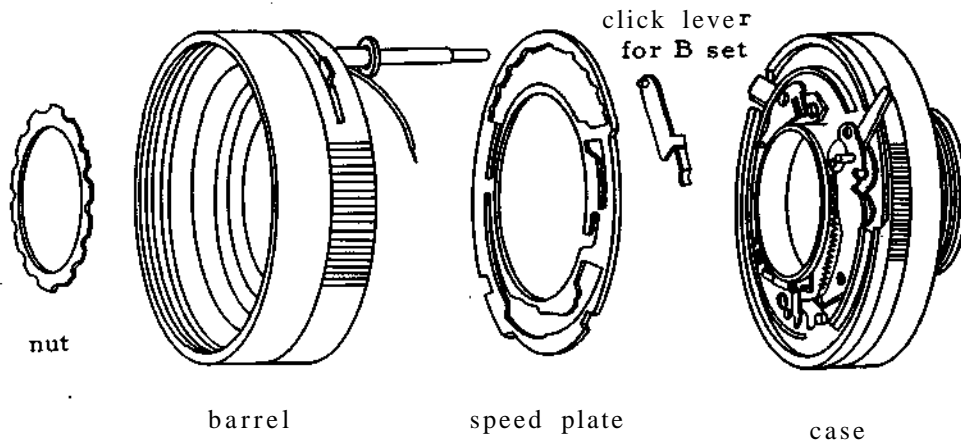

### Works

Taking out Barrel

Taking out Speed Plate

Taking out Click Lever  
for B Set

### Specifications

Fit the nut to the screw.

Taking out nut.

n.b. Use a pincers or pin face screwdriver for the purpose.

Taking out barrel.

Taking out speed plate.

Taking out Click Lever for B Set.

## SHUTTER BLADES DISASSEMBLING

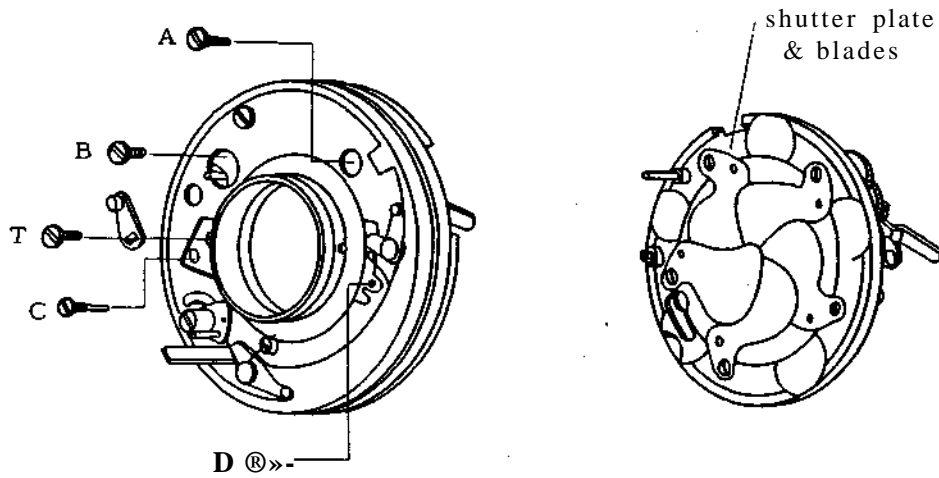

### Works

### Specifications

Taking out Set Lever

Taking out screw.  
T

Taking out set lever.

n. b. The set lever should be taken out pushing the top end up -with screwdriver.

Taking out Plate

Taking out screw x 4.  
A, B, C, D

Taking out plate.

It can be taken out in the state of shutter blades being assembled to the plate.

## DIAPHRAGM BLADES DISASSEMBLING

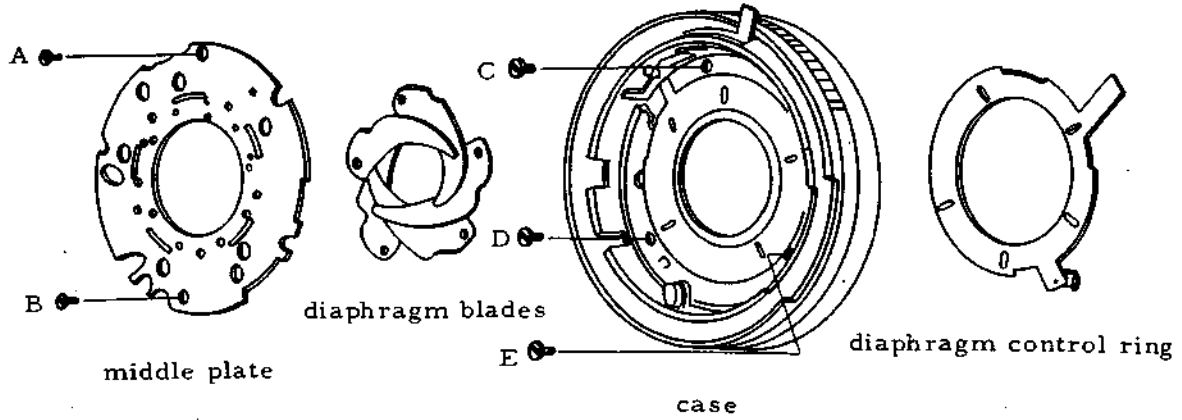

### Works

### Specifications

Taking out Diaphragm

Taking out screw x 2  
A, B

Taking out middle plate

Taking out diaphragm blades (5 blades).

Taking out Diaphragm Control Ring

Taking out screw x 3  
C, D, E

Taking out Diaphragm Control Ring

## DIAPHRAGM RING DISASSEMBLING

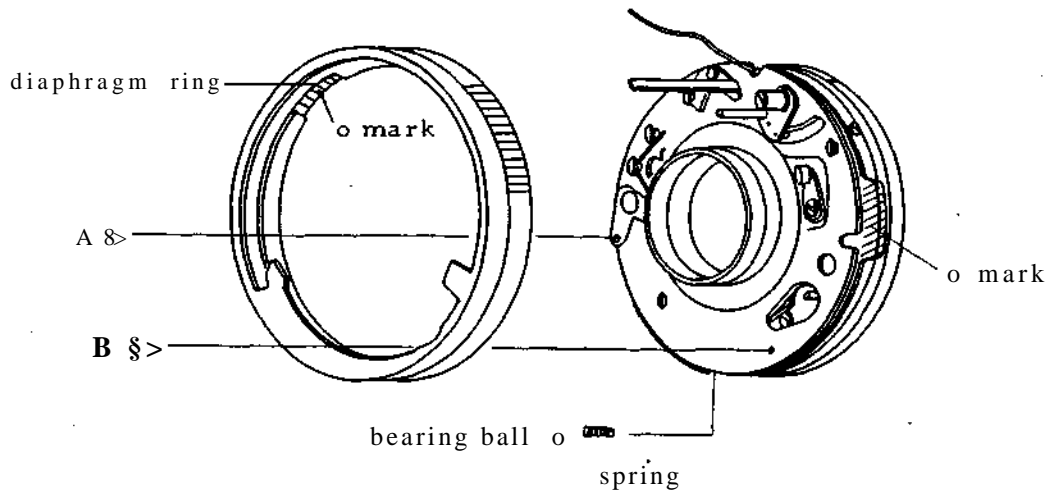

### Works

Taking out Screw x 2

Letting Diaphragm Ring Revolve

### Specifications

Taking out screw A and B.

Revolve the diaphragm ring direction of counter-clockwise to the shutter body about the position specified in the following diagram.

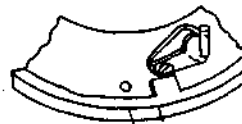

approx. 5mm

Taking out Diaphragm Ring

The diaphragm ring can be taken out at the position where two o marks come together.

n.b. Pay attention lest bearing ball and spring should be lost, bearing ball plays an role of auto click.

## RELEASE LEVER ADJUSTMENT

### How to Disassemble

#### 1 Taking out M-Governor Driver

- 1) Taking out spring
- 2) Taking out nut

Take out the nut holding governor driver with your fingers from the top as the position of adjusting tap should not get out of position.



nut



governor driver



adjusting tap

#### 3) Marking

Put a mark to the governor drive and adjusting tap as the assembling position should be easily identified.



#### 4) Taking out M-Governor Driver

- 5) Taking out adjusting tap

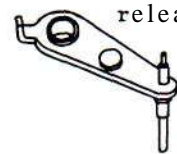

release lever

#### 2 Taking out release lever

- 1) Taking out spring
- 2) Taking out release lever

### Inspection

- 1 Insertion of shaft must be smooth.
- 2 There should not be any scratch and roughness on the surface where release hook touches.



release lever shaft

### How to Fix

- 1 Put MOG-3 to the release lever shaft.
- 2 Put MOG-3 to the release lever hook part.
- 3 Fix the release lever and spring.
- 4 Fix the adjusting tap.
- 5 Fixing governor driver.
- 6 Fastening nut

Putting the mark of governor driver and adjusting tap together and fasten holding governor driver with your fingers lest the position of tap should move.

7 Check gearing of release

Refer to the item how to replace and adjust tension.

8 Fixing B lever.

## M-GOVERNOR ADJUSTMENT

### How to Disassemble

- 1 Taking out B lever.
- 2 Taking out M-Governor Driver.

Refer to the item how to replace and adjust release .

- 3 Taking out segment gear.
  - 1) Screw
  - 2) Segment gear

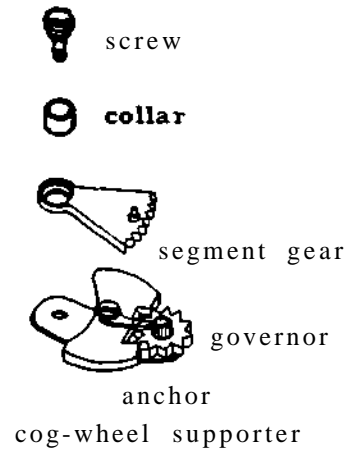

### Inspection

- 1 Space between cog-wheel supporter and anchor must be less than 0.15mm.
- 2 Operation of anchor and cog-wheel must be smooth.

### How to Fix

- 1 Fixing governor
  - 1) Put the governor on plate.
  - 2) Segment gear collar
  - 3) Segment gear
  - 4) Screw
  - 5) When holding the dowell and letting it move to right and left, it should operate smooth without any pulling.

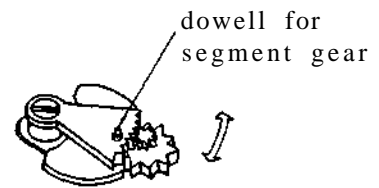

Gear space between segment gear and cog-wheel can be adjusted to some extent.

- 2 Fixing governor driver

Refer to the item how to replace and adjust release lever.

- 3 Check release gearings.

Refer to the item how to replace and adjust tension.

- 4 Fixing B lever



## SHUTTER BLADES ADJUSTMENT

### How to Disassemble

- 1 Take out the spring from spring hanger.

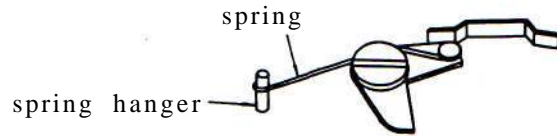

- 2 Take out tension lever in the state that shutter is depressed.
- 3 Take out four screws which fix plate.

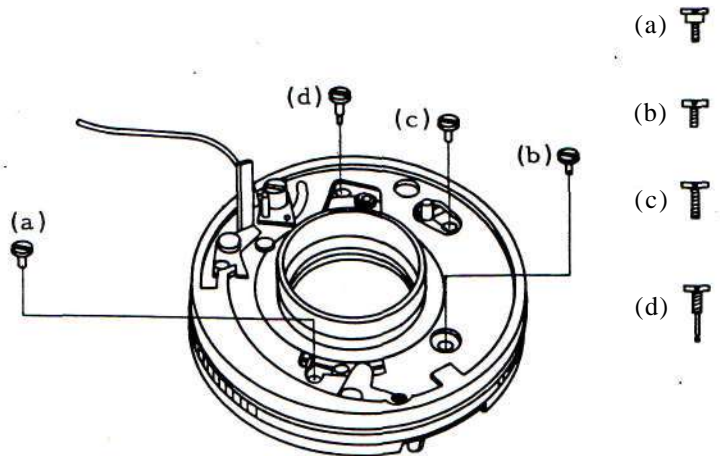

- 4 Set dowell for M-Governor Driver at the point a little farther near to X than M position.

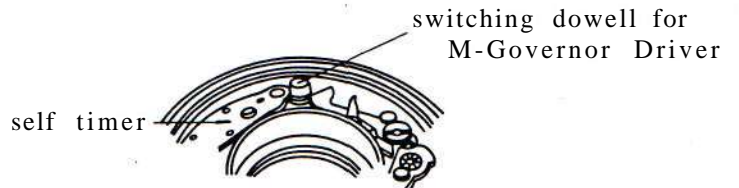

Scratched blades, dirt, oily, fingerprints

### Inspection

- 1 Plate

- 1) Put CU087 Rear Lens to the plate.

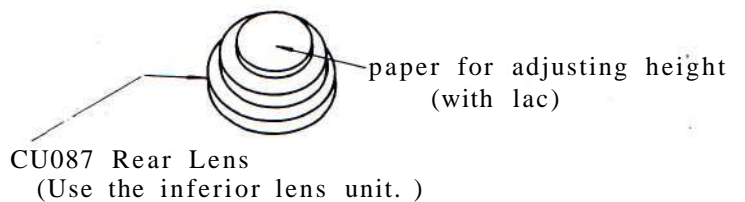

2) Assembling sub shutter blade

Assemble as shown in the diagram (a)-(d).

3) Assembling shutter blades

Assemble as (a) - (e). clockwise direction.

Assemble the last sub blade on the blade (e).

n.b. Pay attention not to put any fingerprints' on it.

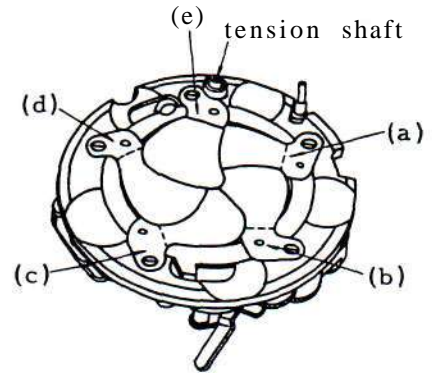

2 Case

Check setting position of M-Governor Driver switching dowell. The position should be a little farther near to X than M position.

3 Assembling plate and case

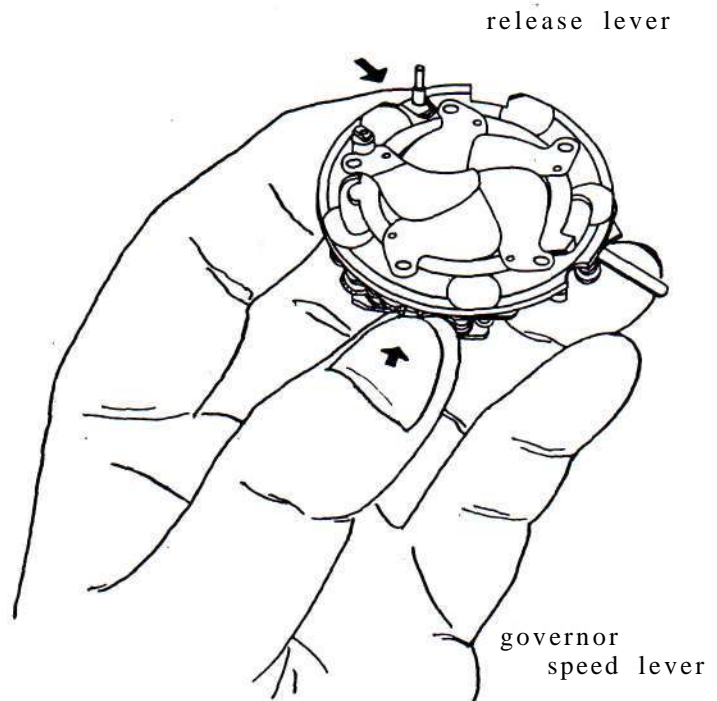

- 1) Hold the plate with your left hand as shown in the diagram, and press the release lever in with your forefinger. In this stage pay attention if it is inclined, the assembled blades come off.
- 2) Hold it in the direction which the case is fitted to the plate, and fit the release lever pin and long hole for the pin.

- 3) Placing the case and the plate in parallel, assemble in until the height of release pin's top end becomes same level as the oblique lines portion of the diagram.

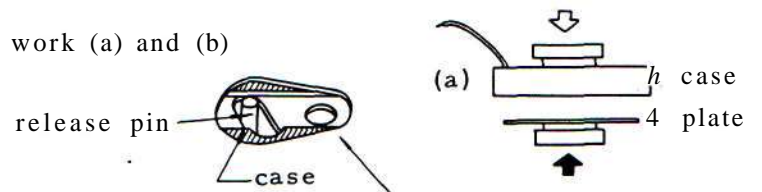

- 4) Assemble synchro side tightly  
work (c)

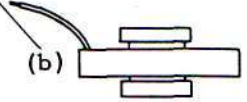

- 5) Being synchro side closely fitted to ....  
work (d)

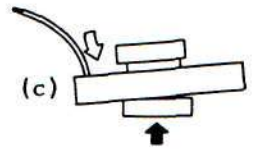

- 6) Assemble the other side (synchro wire side.)

In this stage assemble after M-Governor Driver is properly set.

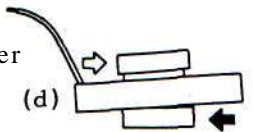

work (e)

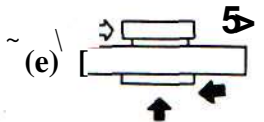

- 4 Fasten four pieces of screw for the plate.

Refer to the item how to disassemble (3) of this section.

- 5 Hanging spring for synchro contact.

Refer to the item how to disassemble (1) of this section.

- 6 Fixing tension lever

Put a little lac to screw hole of tension shaft.

- n.b. 1 Put correctly the pieces of washer which have been inserted.  
2 Pay attention that lac should not be put to the operation portion.



## DIAPHRAGM BLADES ADJUSTMENT

### How to Disassemble

#### 1 Taking out plate.

Refer to the item how to replace and adjust shutter blades.

#### 2 Taking out blades retaining plate.

- 1) Set the diaphragm regulating ring at Auto.
- 2) Taking out two screws for blades retaining plate.
- 3) Taking out the blades retaining plate.

### Inspection

Scratch, dirt, oil and fingerprints on the blades.

- #### 1 Assemble the blades as the direction shown in the diagram in order of the counter clockwise.

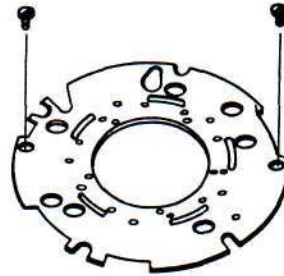

blade retaining plate

- #### 2 Put the blades in order within the case circle.

- #### 3 Fix the blade retaining plate.

- #### 4 Fasten the screw for the plate.

- #### 5 Check the operation of blades. They should move smoothly without any pulling.

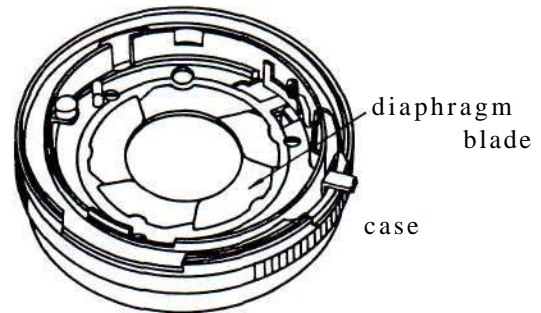

- #### 6 Fixing plate.

Refer to the item how to replace and adjust shutter blades.

## MAIN COCKING LEVER ADJUSTMENT

### How to Disassemble

#### 1 Taking out slow governor

- 1) Set the cocking lever.
- 2) Take out three screws for the governor.
- 3) Take out the governor.
- 4) Take out washers

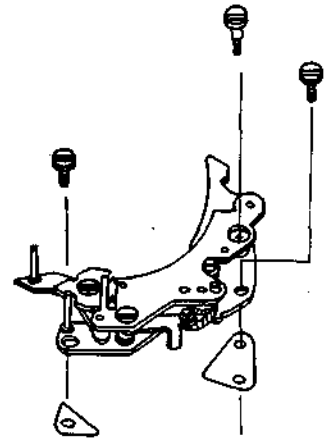

I slow governor

#### 2 Taking out the main cocking lever

- 1) Take out tension spring.



Take out the spring to the arrow direction using a screwdriver,

- 2) Pull out the main cocking lever.

n.b. Pay attention as the synchro contact should not be bent when it pulls out.

### Inspection

- 1 The move of piston should be smooth.
- 2 Every surface should be smooth.

### How to Fix

- 1 Put MOG-3 on the tension.

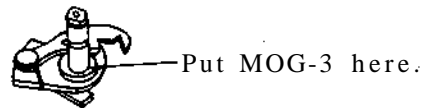

Put a little MOG-3 on the brim.

- 2 Fix the main cocking lever •

Push in the main cocking lever on the way of the extent that spring hang tool can be inserted.

- 3 Hang the spring hang tool to rise up portion of tension spring and hang it to portion (a) of the main cocking lever pulling the spring.

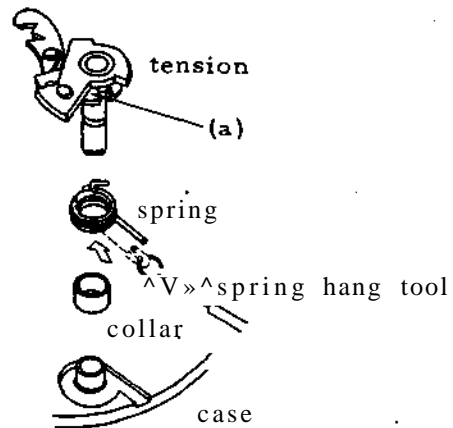

- 4 Press the main cocking lever completely down.  
If it is hard, insert it in pushing the tension spring to the arrow direction with pincers.
- n. b. 1 Pay attention as the spring should not be weakened.  
2 Pay attention to the bending of contact.
- 5 Fix rear cocking lever.

Put a little lac to screw hole of main cocking lever shaft.

- n. b. Pay attention as lac should absolutely not be put to the operation portion.

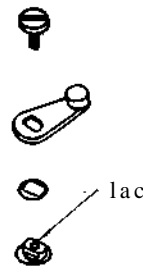

- 6 Put MOG-3 to the main cocking lever  
Put a little MOG-3 to the (a), (b) portion in the diagram.

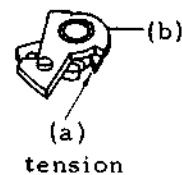

## 7 Gearing of release lever and main cocking lever

1) Set the cocking lever.

2) Letting the piston operate to the arrow direction and check if it touches to semicircle.

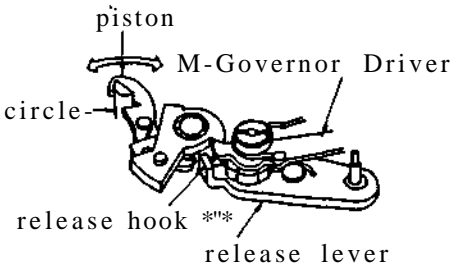

3) If it touches, adjust bending the release hook to the arrow direction.

4) Timing of piston, setting of semicircle, tension, and release hook

- i As a rule the release and piston should be charged simultaneously,
- ii It may have some divergence, however, it should not extremely be different, because it causes that synchro contacts when the contact moves and sets.
- iii In that case the piston should charge in the first place.

5) Room

It requires some room space after charge.

## TROUBLE, CAUSE & REMEDY

### IT CANNOT BE RELEASED.

- |   |                                       |     |  |
|---|---------------------------------------|-----|--|
| 1 | The blades do not move.               | 1-1 | <b>Oil</b><br>Clean.   |
|   |                                       | 1-2 | <b>Metal collapse</b><br>Replacement<br>Refer to the item of shutter blades adjustment.                        |
| 2 | The main cocking lever does not move. | 2-1 | <b>Creaking main cocking lever shaft</b><br>Replacement<br>Refer to the item of main cocking lever adjustment. |
|   |                                       | 2-2 | <b>Rusting main cocking lever</b><br>Replacement<br>the same as the above                                      |
| 3 | Inferior Piston Move                  | 3-1 | <b>Coming off piston spring</b><br>Correct the hanging.<br>Check the spring movement.                          |
|   |                                       | 3-2 | <b>Adjusting aberration</b><br>Refer to the item of main cocking lever adjustment.                             |
|   |                                       | 3-3 | <b>The piston does not move.</b><br>Replacement<br>the same as the above                                       |
| 4 | An obstacle be caught in.             |     | Abridged   |

### HEAVY RELEASE

- |   |  |     |  |
|---|--|-----|--|
| 1 | Roughness of Release Hook and Main Cocking Lever | 1-1 | <b>Lack of oil on the touching surface</b><br>Lubricate MOG-3 on the surface.  |
|   |  | 1-2 | <b>Roughness of the touching surface</b><br>Replacement<br>Refer to the item of release lever and main cocking lever adjustment. |
| 2 | Inferior Operation of                            | 2-1 | <b>Bent release lever</b><br>Adjustment<br>Check the gearing of rear release and tension.  |



- |                         |     |   |
|-------------------------|-----|---|
|                         | 2-2 | Rusted release lever<br>Replacement<br>Refer to the item of release lever adjustment.                 |
| 3 Inferior Release Ring | 3-1 | Rough surface of release pin<br>Polish using oil stone and after that put a little liquid molybdenum. |
|                         | 3-2 | Rough surface where touches to the helicoid<br>The disposal is same as mentioned in 3-1.              |
|                         | 3-3 | Bent release ring<br>Rectifying or replacement  |

IT CANNOT BE CHARGED.

- |                                 |     |   |
|---------------------------------|-----|---|
| 1 Coming off Main Cocking Lever | 1-1 | Loosened screw<br>Refer to the item of main cocking lever adjustment.   |
|                                 | 1-2 | So much room space in the tension lever long hole<br>the same as the above  |
| 2 Inferior Piston Move          | 2-1 | The piston does not move.<br>Refer to the item of main cocking lever adjustment.  |
|                                 | 2-2 | Coming off piston spring<br>Hang it up and check the effect of spring.  |
| 3 Inferior Release Lever Move   | 3-1 | Bent release lever<br>After adjustment, check the gearing of release and main cocking lever.<br>Refer to the item of main cocking lever adjustment. |
|                                 | 3-2 | Inferior release spring<br>Replace it and refer to the item of release, lever adjustment.   |
|                                 | 3-3 | Rusted release lever<br>Replace and the rest is same as the above.  |

CHARGE IS HEAVY.

- |   |  |     |   |
|---|--|-----|---|
| 1 | Rough Surface of Main Cocking Lever with Release Lever | 1-1 | Lack of Lubrication<br>Lubricate MOG-3 to the touching surface.   |
|   |  | 1-2 | Rough surface<br>Replace main cocking lever and release lever.<br>Refer to the item of main cocking lever and release lever adjustment. |
| 2 | Creaking Main Cocking Lever Shaft                      | 2-1 | Lack of Lubrication<br>Lubricate MOG-3 to the tension shaft.<br>Refer to the item of main cocking lever adjustment.                     |
|   |  | 2-2 | Rough tension shaft<br>Replacement<br>the same as the above   |
|   |  | 2-3 | Rusted tension shaft<br>Replacement<br>the same as the above  |
| 3 | Rear cocking lever touches to rear cover plate .       | 3-1 | Bent rear cocking lever<br>„<br>Replacement<br>Refer to the item of main cocking lever adjustment.                                      |
| 4 | Inferior M Governor                                    | 4-1 | Cog-wheel has been detached and it touches to connection plate.<br>Adjustment<br>Refer to the item of M Governor adjustment.            |
|   |  | 4-2 | Loosened segment gear screw<br>Adjustment<br>the same as the above  |
|   |  | 4-3 | Lack of lubrication on cog-wheel<br>Lubrication   |

DIAPHRAGM BLADES DO NOT RETURN.

- |   |              |  |
|---|--------------|--|
| 1 | Oil          | Cleaning   |
| 2 | Stuck Blades | 2-1  |
|   |              | Inferior stopper position<br>After adjustment: 1 Stop down fully up to f 16 by manual lever. |

2 At this time check if the auto lever moves smoothly without any catching.

2-2 Warping  
Replacement  
Refer to the item of diaphragm blades adjustment.

2-3 Scratch  
Replacement  
the same as the above

3 Transformation by Shock

Refer to the item of diaphragm blades adjustment.

4 Detached Spring

Hang it up.

DIAPHRAGM BLADES DO NOT RETURN SMOOTHLY.

1 Oil

2 Inferior Operation of Auto Diaphragm Lever

2-1 Loosened screw  
abridged

2-2 It touches to the case because of bending.  
Replace the auto lever.

2-3 Rusted  
the same as the above

3 Inferior Operation of Manual Diaphragm Lever

3-1 Lubricate and clean.

3-2 Replace in case of inferior revetting.

3-3 Replace in case of rusting.

B FULL OPEN

1 Inferior Governor

Refer to slow skipping.

2 Connection of B Lever and Main Cocking Lever

2-1 Stuck  
Replace B lever.

2-2 Rough surface  
Replace B lever and main cocking lever.  
Refer to the item of main cocking lever.

3 Creaking Sector Ring

Most of this trouble being caused by shock.

Replacement  
Refer to the item of shutter blades adjustment.

4 An obstacle has been stuck.  
abridged

B SKIPS.

1 Inferior Operation of B Lever  
Replacement

2 Warped Cam Plate  
Rectify.

ONE SECOND OPEN

1 Inferior Governor  
1-1 Loosened governor set screw  
abridged

1-2 Lack of lubrication on anchor  
Lubricate.

1-3 Aberrant adjustment for anchor  
Adjust.

1-4 Connection plate is too loose.  
Replace governor.

1-5 There is an obstacle in gear  
Rinse by benzine and then lubricate.

2 Creaking Sector Ring  
Most of this trouble being caused by shock;

3 An obstacle has been stuck  
abridged

SLOW SKIPS.

1 Inferior Governor  
1-1 Operation of anchor clutch lever  
Replace governor.

1-2 Put in anchor clutch lever pin.  
After being adjusted the bending of clutch lever,  
and then adjust the clutch space.

1-3 Anchor clutch lever pin is too high,  
the same as the item 1-2

1-4 Inferior operation of speed change lever  
Replace governor.

1-5 Loosened revetting of pinion gear  
Replace governor.

1-6 Creaking of connection plate

IT CANNOT BE RELEASE  
SELF-TIMER.

1 Inferior Operation of  
Clutch Lever

1-1 Bent clutch lever  
Rectify bending.

1-2 Detached clutch lever and sector ring's dowell  
Adjustment

2 Bent Safety Lever

Hold the end of safety lever with pincers and rectify  
the bent base by pushing in a screwdriver.

3 Self gear gets dirty.

Rinse by benzine and they lubricate.

4 An obstacle has been  
stuck.

abridged

# CANON SERVICE TOOL MANUAL

CANONET

(REFERENCE NO. C-30206)

CANON CAMERA COMPANY, INC.

TOKYO, JAPAN

## CONTENTS

HOW TO USE .....

THE LENS PROJECTION TEST UNIT

THE 200mm T TYPE COLLIMATOR

THE LENS SHUTTER TESTER

THE INSPECTION DEVICE FOR CANON METER

THE LOCATING JIG FOR THE EE-DRIVING SHAFT

THE SPANNER-2 FOR C4041

LIST OF SPECIAL SCREWDRIVERS FOR CANONET

## HOW TO USE THE LENS PROJECTION TEST UNIT

### 1. NAME OF THE TOOL

Lens Projection Test Unit

### 2. PURPOSE

When the Canonet is overhauled, for example, by disjoining the front panel with objective from the body or by disassembling the front panel with objective lens, it is necessary to adjust and reassemble them, while testing, in the following method of test:

- (a) Correct adjustment shall be made of the focal plane of the camera in the same method as adopted for the 200mm T Type Collimator.
- (b) Test and adjustment shall be conducted, through the use of the Lens Projection Test Unit, as to whether the lens is correctly fitted in the camera body.

This formula may be applied also to the checking of the customers' claims regarding the quality of the lens.

It is necessary, however, to prevent the participation in the test work by those customers who have little technical knowledge; otherwise it may cause an unnecessary conflict with them.

### 3. TO BE USED FOR

Canonet

### 4. COMPOSITION

- (1) The Lens Projection Test Unit 1

The Lens Projection Test Unit refers to the equipment for use in the test of the Canon Lens and Canon Cine Lens, which has already been supplied, with the exception of its attachment; so the Test Unit is not supplied with the recently-introduced Lens Projection Test Attachment-2.

- (2) The Lens Projection Test Attachment-2 1

- (3) Screen 1

This projection test screen is not supplied with the Lens Projection Test Attachment-2. White mat art paper pasted up on a wall, a white wall as such, or a suitable cine screen may be used as the projection test screen.

Its standard size shall be about 75cm by about 110cm, but it is desirable for its surface to be even.

This is because it is difficult to discern any image on a screen the surface of which is rough.

### 5. OUTWARD APPEARANCE

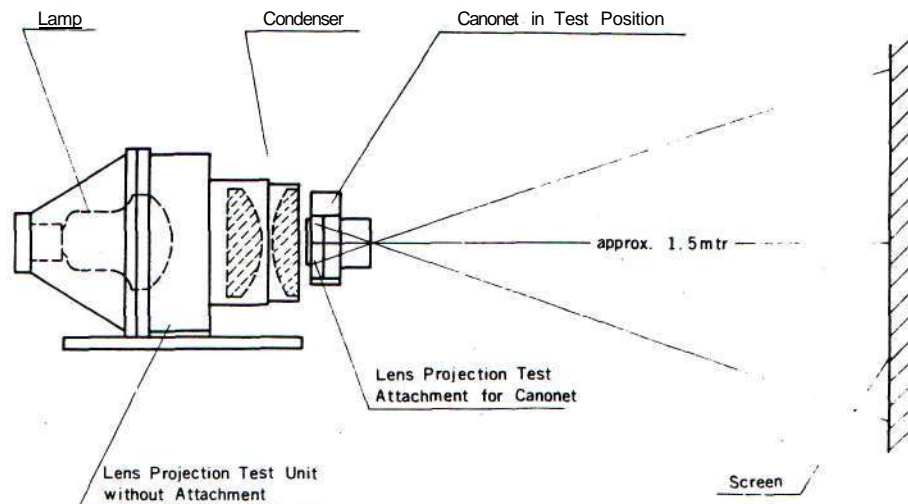

Fig. J The method of (he lens Projection Test for Canonet



## 6. HOW TO USE

- 6.1. The Lens Projection Test Unit without attachment shall be placed on a desk the surface of which is even, a screen being set right ahead of the desk. In this case, the Test Unit shall be made to face just toward the screen with a space of about 1.5 m left. The screen shall be about 75cm x about 110cm in size.
- 6.2. The lens shall be opened to F1.9 with the shutter kept to Time exposure.
- 6.3. The Lens Projection Test Attachment-2 shall be fixed in the back of the camera body by opening its back cover so as to be stuck close to the rail. In this case, the center of the Test Attachment shall be trained right on the optical center of the lens. In handling the Lens Projection Attachment, you must keep your fingers off the plateglass, especially the test chart.
- 6.4. The Lens Projection Test Unit shall be switched on.
- 6.5. The camera body shall be maintained so that the distribution of light intensity through the camera in the test position can be equivalent. In this case, a suitable holder may be used.
- 6.6. The helicoid of the lens shall be adjusted so that the test chart's image on the screen can be discerned most clearly.
- 6.7. If the test chart is imaged equally on the screen both vertically and horizontally, then it may safely be said that the lens is fixed properly to the camera body.

It is necessary, however, to note that tolerance, however slight it may be, is considered in proportion to the ratio of photographing. Even if at first sight the lens is fitted in the camera body in the wrong way, sometimes it need not be taken seriously if the ratio of photographing is taken into consideration in examining the image on the screen.

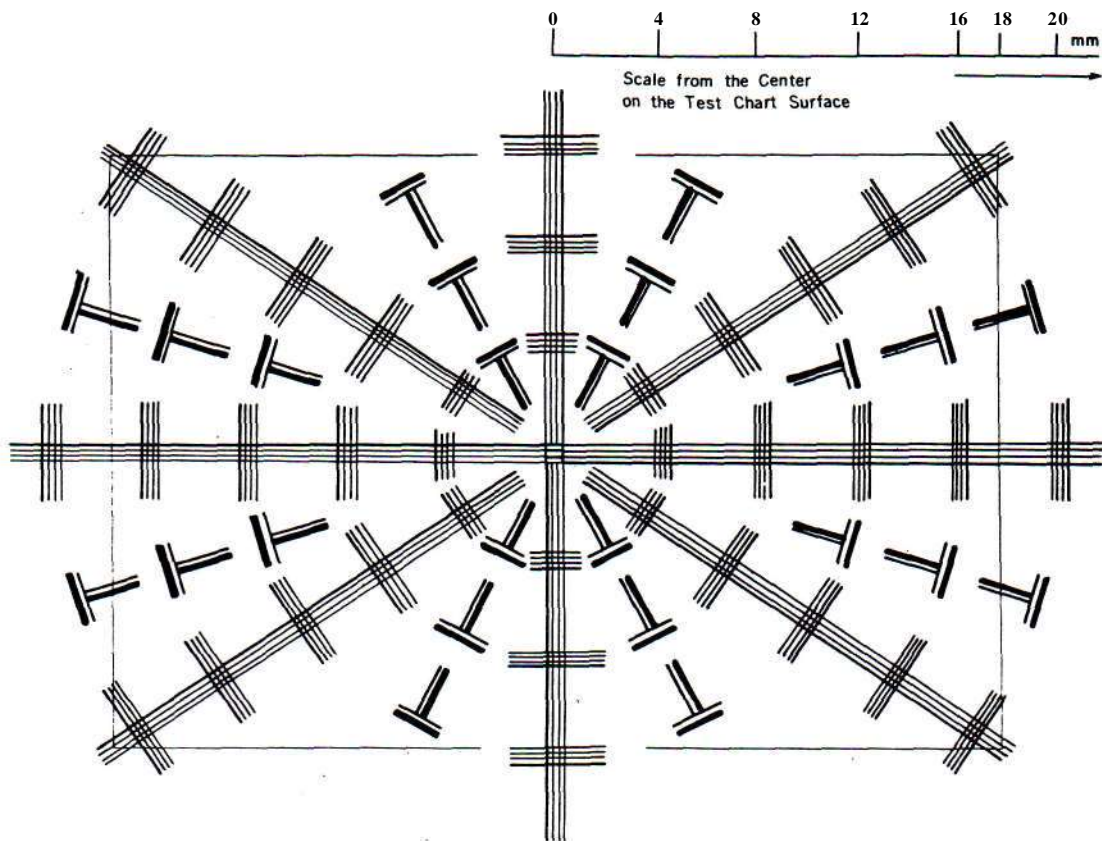

Fig. 2 The Diagram of ffie Test Chart

## HOW TO USE THE 200mm T TYPE COLLIMATOR

1. NAME OF THE TOOL

200mm T Type Collimator

2. PURPOSE

In repairing the Canonet, when the front panel with objective lens has been removed from the body or when front panel with objective lens has been further dismantled, a 200mm T Type Collimator must be used to adjust the helicoid so that the focal plane will be accurately maintained.

3. TO BE USED FOR

Canonet

4. COMPOSITION

- |   |   |
|---|---|
| (1) 200mm T Type Collimator (collimator, pole, stand) | 1 |
| (2) Mirror  | 1 |

5. OUTWARD APPEARANCE

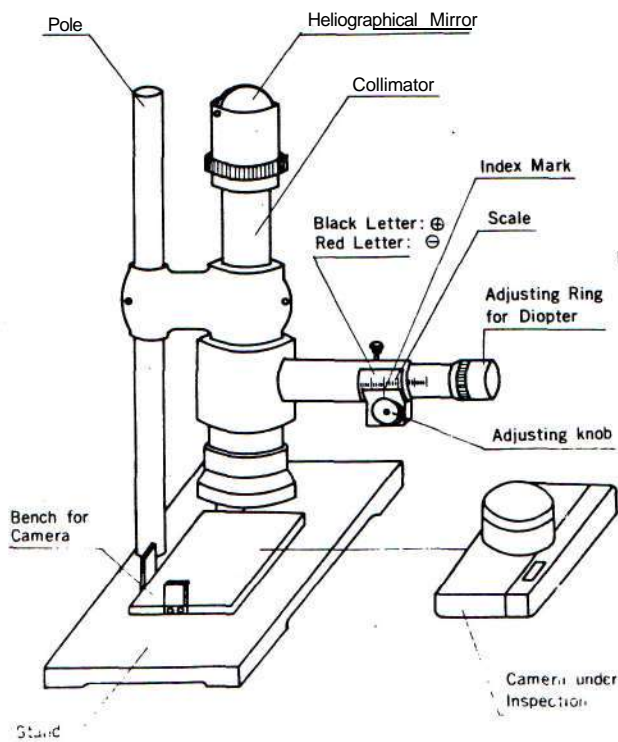

Fig. 1 The Appearance of the 200mm T Type Collimator

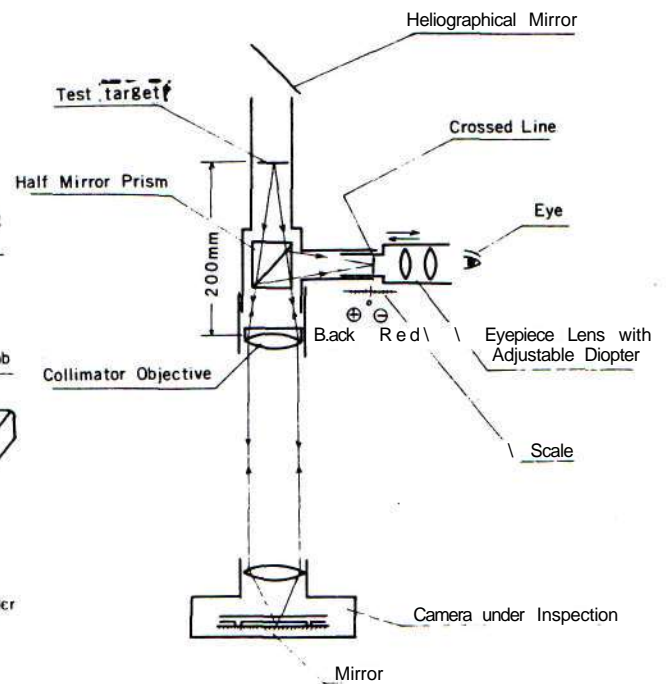

Fig. 2 The Illustration of the optical construction of the 200mm T Type Collimator

## 6. HOW TO USE

6. 1. Place the stand of the 200mm T Type Collimator on a flat table, set up the pole and attach the collimator to the pole.
6. 2. Place the mirror on the bench of the stand. Next, turn the heliographical mirror and adjust so that the field of vision is brightest. It is most desirable to use natural light.
6. 3. Turn the adjusting ring for the diopter and adjust so that the crossed line within the field of vision is clearest.
6. 4. Turn the adjusting knob directly underneath the scale and find the position in which the test target picture can be seen at its clearest.

The test target picture should be clearest when the scale is at the "0" position, but adjustment is not very easy until one gets used to it. Practice is necessary.

6. 5. After the camera has been assembled, place the mirror against the camera's film plane position and close the back cover. Have the reflecting surface of the mirror facing toward the lens side.
6. 6. Open the lens aperture to F1. 9, set the distance scale to infinity set the shutter speed to T (time) and open the shutter.
6. 7. Place the camera with the top cover toward you on the bench.
6. 8. Turn the adjusting knob directly underneath the scale and find the position in which the test target picture can be seen at its clearest.

If this position is between 8 and 10 on the black letter side, you are guaranteed of correct focusing of your camera.

## 7. HOW TO ADJUST

7. 1. If this position is not between 8 and 10 on the black letter side, take the following steps:
7. 2. Adjust the scale of the 200mm T Type Collimator to 9 on the black letter side.
7. 3. Loosen the lock screw S3787 of the camera's focusing ring C4256.

*See Repair Manual p. 6.*

7. 4. Place the camera on the bench. While looking at the field of vision, place your fingers on the focusing knob and turn the helicoid slowly, either clockwise or counter clockwise.

Turn the helicoid until you find the position in which the test target picture is clearest.

7. 5. Make the infinity mark oo of the focusing ring C4256 coincide with the distance scale index and then tighten the lock screw S 3787.

*See Repair Manual p. 6.*

7. 6. Repeat the inspection outlined in 6. 8. •

## HOW TO USE THE LENS SHUTTER TESTER

1. NAME OF THE TOOL

Lens Shutter Tester

2. PURPOSE

The Lens Shutter Tester is used to test the performance of the shutter of the camera with the lens shutter.

3. TO BE USED FOR

Canonet

4. COMPOSITION

- |                               |   |
|-------------------------------|---|
| (1) The Lens Shutter Tester A | 1 |
| (2) The Lens Shutter Tester B | 1 |
| (3) Cable Cord                | 1 |
| (4) Sync-Cord                 | 1 |
| (5) Lamp 24V 20W              | 1 |
| (6) Fuse 1A                   | 1 |

5. OUTWARD APPEARANCE

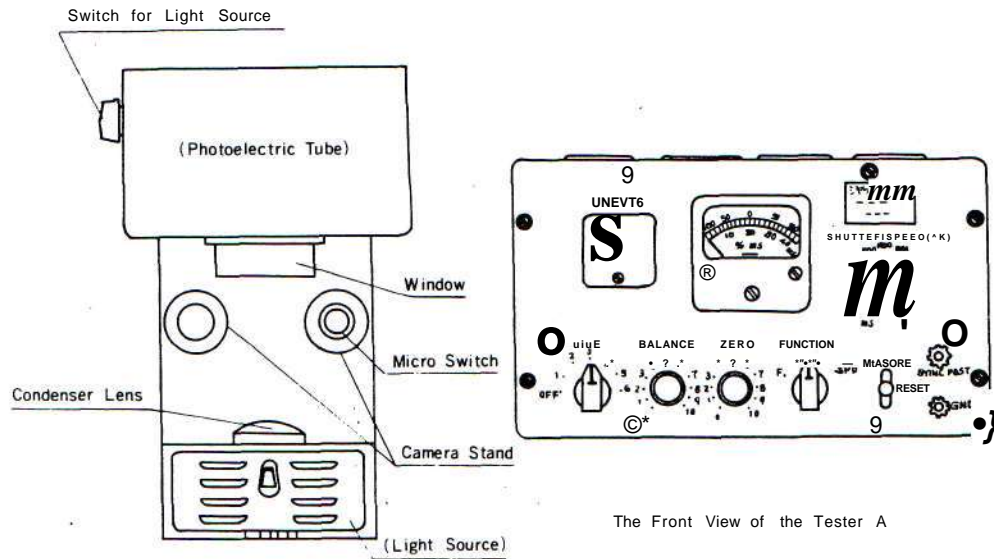

*The Appearance of the lens Shutter Testers*

6. HOW TO USE

6. 1. Place the Lens Shutter Testers A & B on a flat table. Be careful not to let the intense light rays fall on the photoelectric tube of the Tester B.
6. 2. Connect the Testers A and B with the Cable Cord.
6. 3. Connect the Tester A with source of electricity.
- 6.4. Turn the LINE dial of the Tester A to the right and adjust the needle of the LINE VTG meter so that it gets into the red part.
6. 5. Wait for a few minutes until the Testers become settled.
- 6 6. Put the MEASURE lever of the Tester A on RESET and adjust the needle of the meter so that it points to-100,

by turning the ZERO dial.

Then, put the lever on MEASURE and, if the needle gets out of -100, adjust it by turning the BALANCE dial.

6. 7. Adjust the height of the camera stand of the Tester B so that the center of the shutter of the camera and that of the window of the Tester B come on the same point.



The stand will become higher when you turn this part to the left.

When you get suitable height, turn this part to the right and fix the stand.

6. 8. Set the LIGHT dial at 1.

6. 9. How to Measure the Shutter Speed.

6. 9. 1. Set the FUNCTION dial at SPD.

6. 9. 2. Set the MEASURE lever at MEASURE.

6. 9. 3. Set the SHUTTER SPEED dial at 1.

6. 9. 4. Set the aperture ring of the camera at open (F1. 9) and the shutter speed ring at 1.

(The SHUTTER SPEED of the Tester A and the shutter speed of the camera should be always the same.)

6. 9. 5. Open the hinged back of the camera.

6. 9. 6. Place the camera on the camera stand. (The lamp will be lighted.)

6. 9. 7. Press the shutter button.

6. 9. 8. The needle of the meter should indicate the value in the standard range (—30—1-30(%)). (Read the value on the upper scale.)

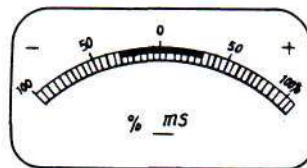

6. 9. 9. The needle of the meter will return to —100 if you return the MEASURE lever to RESET after measuring.

6. 9. 10. Measure various shutter speeds in the same way.

6. 9. 11. If the shutter speed gets out of the standard range, parts must be exchanged as it is difficult to adjust the shutter speed itself.

6. 10. How to Measure the Time Lag of the X Contact.

6. 10. 1. Set the FUNCTION dial at X.

6. 10. 2. Set the MEASURE lever at MEASURE.

6. 10. 1 Set the SHUTTER SPEED dial at m. s.

6. 10. 4. Connect the red cord of one end of the Sync-Cord with SYNC. POST, the black one with GND and another end with the flash socket of the camera.

6. 10. 5. Set the aperture ring of the camera at full open (F1. 9) and the flash setting lever at X. (Any shutter speed will do.)

6. 10. 6. Open the hinged back of the camera.

6. 10. 7. Place the camera on the camera stand.

6. 10. 8. Press the shutter button.

6. 10. 9. The needle of the meter should swing in. this condition. The swing of the needle, however, is very small.

(Usually the swing is not more than 0.5 m. s.)

6.10. 10. When you want to read the quantity of the swing, measure it following the directions below.

Set the SHUTTER SPEED dial at 1000.

If - the needle of the meter swings from -100 to 0 when you press the shutter button, the time lag in this case is 1 m. s.

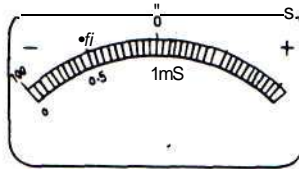

When the SHUTTER SPEED is at 500, it will become 2 m. s.

6. 10. 11. If the needle does not swing, measure it following the direction below because the contact is not on the open position but on some stopped down one.

Turn the aperture ring a little from the open position. Turn the aperture ring to the position which is a quarter from 1.9 to 2.8.

The needle of the meter is expected to swing when you measure on this condition.

6.10. 12. The needle of the meter will return to -100 if you return the MEASURE lever to RESET after measuring.

6. 11. How to Measure the Time Lag of the M Contact.

6.11. 1. Set the FUNCTION dial at M.

6.11. 2. Set MEASURE lever at MEASURE.

6.11. 3. Set the SHUTTER SPEED dial at m. s.

6.11. 4. Connect the red cord of one end of the Sync-Cord with SYNC. POST, the black one with GND and another end with the flash socket of the camera.

6.11. 5. Set the aperture ring of the camera at full open (1.9) and the flash setting lever at M. (Any shutter speed will do.)

6.11. 6. Open the hinged back of the camera.

6. 11. 1. Place the camera on the camera stand. (The lamp will be lighted.)

6.11. 8. Press the shutter button.

6.11. 9. The needle of the meter should indicate the value in the standard range (14.5—19m. s.)

(Read the value by the numbers of m. s. of the lower scale of the meter.)

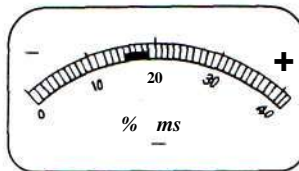

6. 11. 10. The needle of the meter will return to -100 if you return the MEASURE lever to RESET after measuring.

## 7. HOW TO TREAT AND PRESERVE

7. 1. Give neither vibration nor shock to the Lens Shutter Testers.

7. 2. Be careful not to let the intense direct rays fall on the photoelectric tube on the Tester B.

7. 3 Usually, test with the aperture full open.

7. 4. The LIGHT of the Tester B corresponds to the aperture of the camera approximately as follows.

LIGHT	Aperture
1	open-2.8
2	4-11
3	16

The quantity of the swing of the needle of the meter and the brightness of the light source are not related but the Testers cannot work correctly if the brightness of the light source is too much or if it is insufficient.

7. 5. If the needle of the meter does not swing or if it does not return after it swings to another end when you measure X or M contact, examine the brightness of the light source and the condition of the contact of that point.
7. 6. The lamp used as the light source in the Tester B is the one of 24V, 20W(for cars).
7. 7. As the output of the photoelectric tube changes as time goes on, select the suitable LIGHT of the Tester 8, regardless of the correspondence stated on 4. 4. when you measure.

## HOW TO USE THE INSPECTION DEVICE FOR CANON METER

### 1. NAME OF THE TOOL

Inspection Device for Canon Meter

### 2. PURPOSE

The Inspection Device is the apparatus to be used as light source when the performance of Canon Meter and the products which have Canon Meter (e.g. Canonet and Zoom 8) are inspected. It should be connected to power supply, either 100V-125V or 220V-240V, following each direction.

Model 1 100V-125V Projection Lamp 100V 500W

Model 2 220V-240V Projection Lamp 220V 500W

### 3. TO BE USED FOR

Canonet (besides, this Inspection Device can also inspect the Canon Meter of Canon Meter R, Canon Meter 2, Canon 7, Zoom 8 and so on.)

### 4. COMPOSITION

- |   |   |
|---|---|
| (1) The Inspection Device for Canon Meter, Model 1 or Model 2 | 1 |
| (2) Projection Lamp (100V 500W or 220V 500W)                  | 1 |
| (3) Fuse (Model 1 10A, Model 2 5A)                            | 1 |

### 5. OUTWARD APPEARANCE

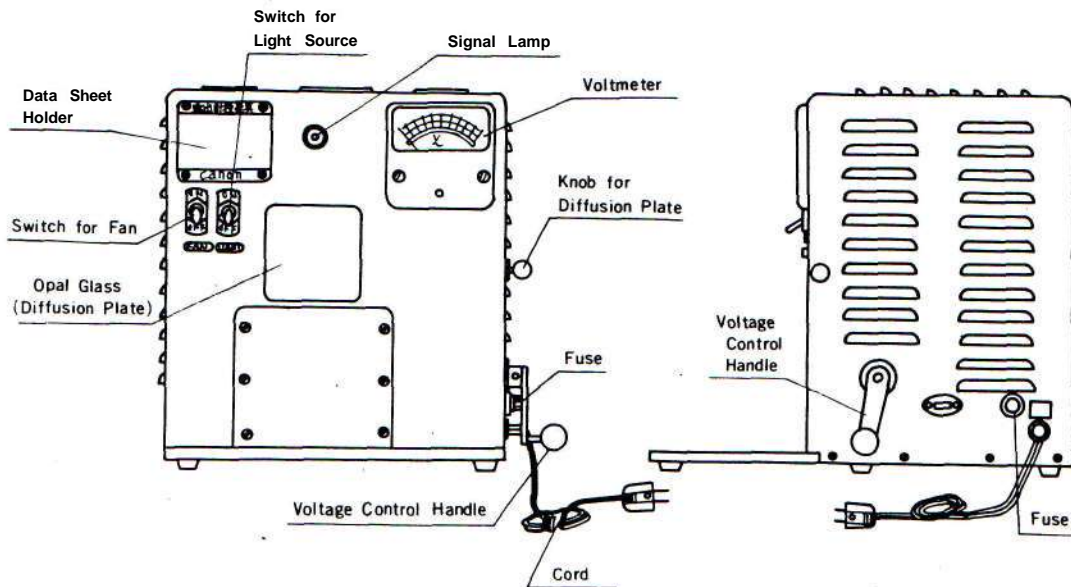

The Appearance of the Inspection Device for Canon Meter



## 6. HOW TO USE

6. 1. Place the Inspection Device for Canon Meter on a flat table where no direct rays of the sun -fall intensely.
6. 2. Make sure that switches for the light source and for the fan are both OFF and the voltage control handle is turned full to the left.
6. 3. Connect the cord to power supply.
- 6.4. When the switch for the fan is put to ON, the fan works and the signal lamp is lighted at the same time.
6. 5. Put the switch for light source to ON.
- 6.6. If you turn the voltage control handle slowly from this side to the opposite (right way round), the light source gradually becomes brighter.

Making it properly bright, measure the accuracy of Canon Meter according to the directions below

### 6. 7. Measure 1

Set the film speed at ASA 100, shutter speed 1/8 and the aperture ring AUTO.

Turn the time ring to the letter T.

Place the meter window equally to the center of the Opal Glass of the Inspection Device.

Boost voltage to the value indicated on the Data Sheet, Term 1, by turning the handle.

(For Reference: The brightness in this case is approximately LV 8, using ASA 100 film.)

Press the shutter button.

Detach the camera from the Inspection Device, watch the diaphragm from the back of the camera opening the hinged back and examine how the aperture' works, following the directions below:

Turn the aperture ring slowly and check the point where the diaphragm begins to work, consulting the calibrated scales on the aperture ring. The aperture should show the value between F4 and F8.

Be sure to return the aperture ring to AUTO after measuring.

### 6. 8. Measure 2

Repeat the same measure with ASA 100 and 1/125, on the condition indicated on the Data Sheet, Term 2.

(For Reference: The brightness in this case is approximately LV 12, using ASA 100 film.)

The aperture should show the value between F4 and F8.

Be sure to return the aperture ring to AUTO after measuring.

### 6. 9. Measure 3

Repeat the same measure with ASA 100 and 1/500, on the condition indicated on the Data Sheet, Term 3.

(For Reference: The brightness in this case is approximately LV 14, using ASA 100 film.)

The aperture should show the value between F4 and F8.

Be sure to return the aperture ring to AUTO after measuring.



Fig. 1

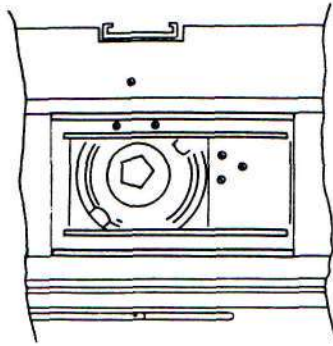

Fig. 2

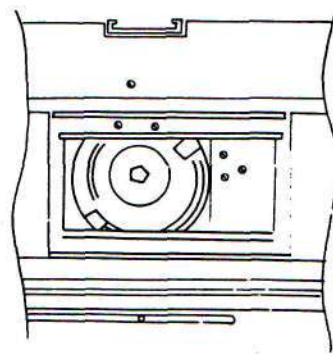

Fig. 3

Note: Fig. 1 Open the hinged back and turn the aperture ring from AUTO to the calibrated scales, watching the diaphragm from the back of the camera.

Fig. 2 The aperture at AUTO on this condition.

Fig. 3 Turning the aperture ring, you will find one point where the diaphragm begins to be stopped down furthermore

**BE SURE TO RETURN THE APERTURE RING TO AUTO AFTER MEASURING!**

## 7. HOW TO INSPECT

7. 1. Keep in mind that the brightness of the projection lamp, the light source of the Inspection Device, changes while being used. For the surface of the lamp becomes black and the quantity of light which falls on the Opal Glass is changed. When the filament of the projection lamp is burnt out, you should check the brightness on the Opal Glass with the new projection lamp you are going to use.

7. 2. Use Canon Meter R which is correctly adjusted as the examining tool.

7.3. How to Examine

7. 3. 1. Choose one of the Canon meter as the standard and check it as soon as the Inspection Device is delivered to you.

7. 3. 2. Check the chosen Canon Meter R on the conditions according to the attached Data Sheet and record the indicated value.

7. 3. 3. Examine from time to time the Inspection Device by the chosen Canon Meter R and revise the voltage indication of each Term on the Data Sheet.

7. 3. 4. When you exchange the projection lamp with a new one, check it with the Canon Meter R above mentioned

7. 3. 5. Be sure that the voltage indicated on the Data Sheet should be correct especially as for the low voltage! (0-40V for 100V and 0-100V for 220V.)

7.4. The projection lamp used in the Inspection Device is that of JIS C 7511 Projection Lamp C 100V 500WS (Metallic Cap F27-22), which corresponds to ASA PH22.851953 Projection Lamp (Dimensions for T10 Bulb)

## 8. HOW TO TREAT AND PRESERVE

8. 1. Give neither vibration nor shock to the Inspection Device.

8. 2. After use, let the voltage fall off to 0 by turning the handle left way round, put the switch for light source to OFF and, after it gets cool, put the switch for the fan to OFF.

8. 3. Avoid as possible lighting continuously for long time.

8.4. Do not let the light from the outside (e.g. the sun, room lamp and so on) influence the Device while using  
(Above all, do not open the top cover and never allow direct rays to fall on the Opal Glass )

## HOW TO USE THE LOCATING JIG FOR THE EE-DRIVING SHAFT

### 1. NAME OF THE TOOL

Locating Jig for the EE-Driving Shaft.

### 2. PURPOSE

Set up and adjust the Lever C9281 of the EE-Driving Shaft of Canonet following the directions below. The Locating Jig is necessary for these cases: when the Screw S3787 which attaches the Lever C9281 to the Driving Shaft is loosened, when the Lever C9281 is to be exchanged and when the front panel with objective lens is to be disassembled, repaired and again assembled.

### 3. TO BE USED FOR

Canonet

### 4. COMPOSITION

(1) Locating Jig

### 5. OUTWARD APPEARANCE

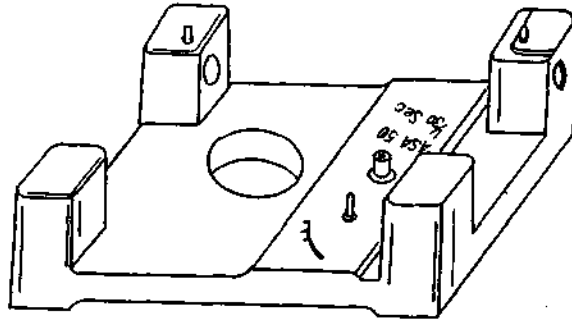

(Front)

### 6. HOW TO USE

6. 1. Set the Locating Jig on a flat table in the position shown above.
6. 2. Set the Film Speed to ASA 50, Shutter Speed 1/30 and Lens Aperture F5.6
6. 3. Attach the front panel with objective lens or the body to the Jig so that pins of the Jig may get into two tapped holes which are under the Front Panel and that the point of the Driving Shaft may get into the guide of the Jig.
- 6.4. Adjust the height of the Lever C9281 so that its flange may touch that of the cradle when the calibration of the range viewfinder is set for the infinity mark oo.
- 6.5. Turn the Lever C9281 until it comes to the stopper position following the arrow of the Locating Jig and then fix the Lever on this point with Screw S3783 x 2.
- 6.6. Fix the Set Screw with special adhesive (Diabond No. 1640);

LIST OF SPECIAL SCREWDRIVERS FOR CANONET



T06A-C4021



For tightening Pin Face Nut C4021  
See Repair Manual p. 5.



T06A-C4036



For tightening Nut C4036  
See Repair Manual p. 5.



T06A-C4104



For tightening Pin Face Screw C4104  
See Repair Manual p. 1.



T06A-C4180



For tightening Bearing C4180  
See Repair Manual p. 3.



T06A-C4181



For tightening Bearing C4181- 02  
See Repair Manual p. 3.



T06A-C4205



For tightening Shaft Screw C4205  
See Repair Manual p. 2.



T06A-C4238



For tightening Nut C4238  
See Repair Manual p. 7.



T06A-C4248



For tightening Nut C4248  
See Repair Manual p. 6.



T06A-C4261

For tightening Assemble Collar C4261  
See Repair Manual p. 6.

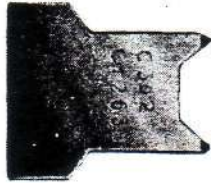

T06A-C4263

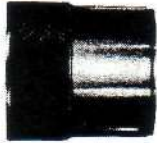

T06A-C4264



T06A-C4265



T06A-C4266



T06A-C4267



T06A-C4331



For tightening Front Lens CU086  
Inner side pin face slot is used.

**See Repair Manual p. 6.**

For tightening Front Lens CU086  
Outer side pin face slot is used.

**See Repair Manual p. 6.**

For tightening Rear Lens CU087  
Outer side pin face slot is used.

**See Repair Manual p. 6.**

For tightening Rear Lens CU087  
Inner side pin face slot is used.

**See Repair Manual p. 6.**

For tightening Collar C4267

**See Repair Manual p. 6.**

For tightening Screw C4331

**See Repair Manual p. 3.**

# CANON SERVICE MATERIALS MANUAL

CANONET

(REFERENCE NO. C-30206)

CANON CAMERA COMPANY, INC.

TOKYO, JAPAN

Following service materials are provided for Canonet. Expressly for the use of the lubricating oil, charts which show the part for each oil to be used are attached.

Lubricant

Grease

Perma-Lube C-3-3 75%

Perma-Lube3005 25%

Perma-Lube IH-1

Mil-G 3278A

Liquid-Molybdenum	<table border="1"> <tr> <td>Mixture of</td> <td rowspan="3">*)</td> </tr> <tr> <td>MH-G3278A 96%</td> </tr> <tr> <td>MoS2 4%</td> </tr> </table>	Mixture of	*)	MH-G3278A 96%	MoS2 4%
Mixture of		*)			
MH-G3278A 96%					
MoS2 4%					

Oil

Squalol L-2

Launa

Adhesive

Diabond No. 1620

Diabond No. 1640

Pliobond

Epoxy resin

White adhesive

Paint

BL-I (Lustrous--for repair painting of the outside.)

BL-I (Lusterless---for defending the internal reflection.)

ATTACHED CHART ( I )

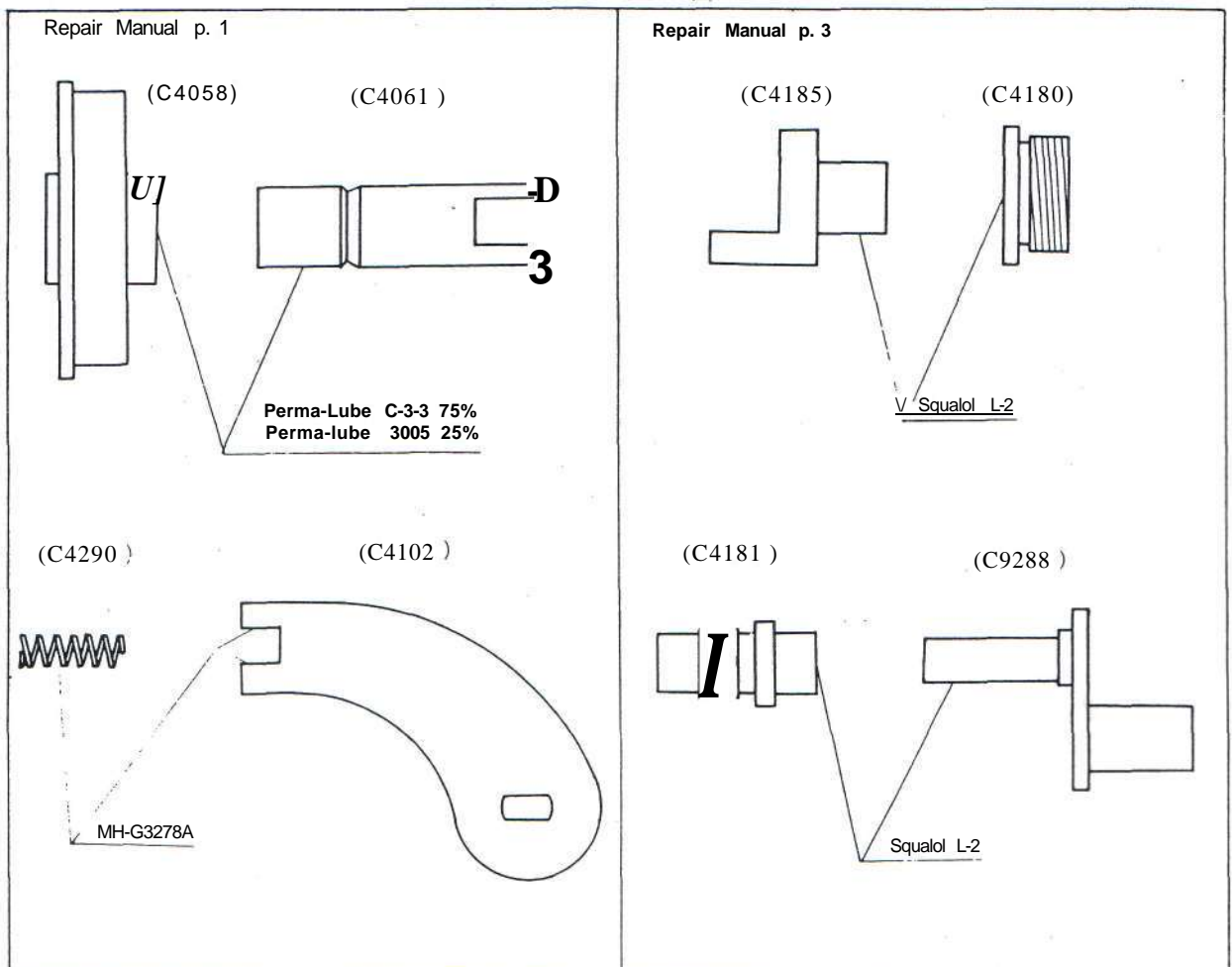

# ATTACHED CHART (H)

Repair Manual p. 4

(C4091)

(C4328)

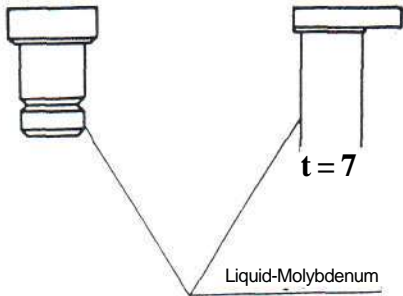

Repair Manual p. 5

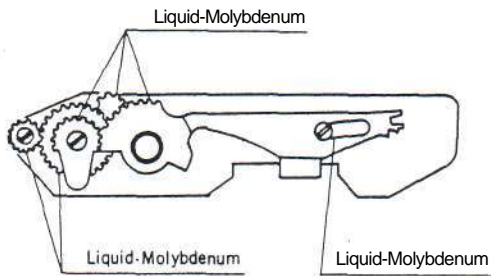

(C 9266)

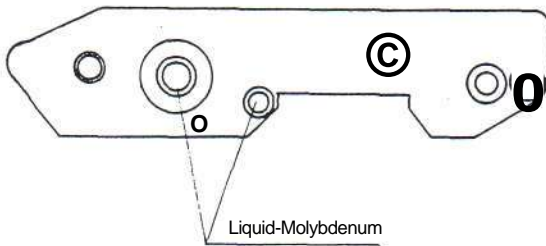

(C 4057)

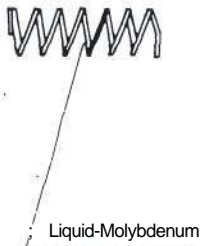

(C 9263)

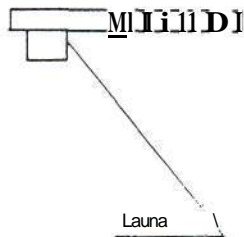

Repak Manual jj.6

(CU086)

(CU087)

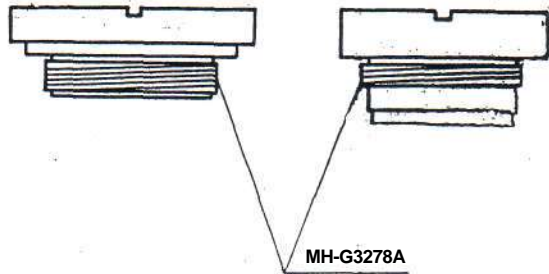

(CU068)

(C4178)

(C 43111)

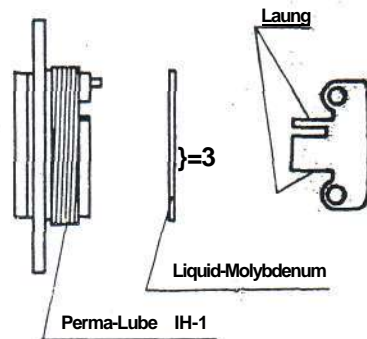

Repair Manual p. 8

(CU 066)

